

Series 3000 SS316 High Pressure Reducing Regulator

INSTALLATION & MAINTENANCE INSTRUCTIONS

WARNING:

Make sure that you have read and understand these directions before using, installing, or maintaining the Series 3000 pressure reducing regulator. Take steps to ensure this instruction manual reaches the operator of this regulator and stays with the regulator throughout its lifetime. Use, installation, operation, and maintenance of all pressurized products including this regulator must be performed by personnel who are properly trained and qualified through experience or specific training.

Failure to properly observe the instructions contained in this document may result in, but is not limited to:

- Serious personal injury or death
- Unconstrained release of the pressurized media
- Permanent damage to the pressure regulator and/or permanent damage to connected equipment.



DESCRIPTION:

The high pressure Series 3000 pressure reducing regulators are single stage, piston sensed, variable delivery regulators designed for inlet and outlet pressures up to 10,000 psig/689 bar(g) and Cv 0.06. Pressure reducing regulators are designed to take a high pressure source and provide a reduced controlled pressure to a system.

Series 3000 regulators are used to regulate a broad range of non-corrosive and corrosive media (based on materials of construction). They are designed for increased serviceability and reliable operation with the integral 15 micron stainless steel valve cartridge filter.

The Series 3000 is a self-relieving regulator that should be used only with compressed gases (not liquids). The Series 3000 is most often used to provide the pilot pressure signal to an Equilibar® back pressure regulator (BPR) but can be used in any application where relatively small volumes of compressed gas pressure must be controlled. See Figure at right.

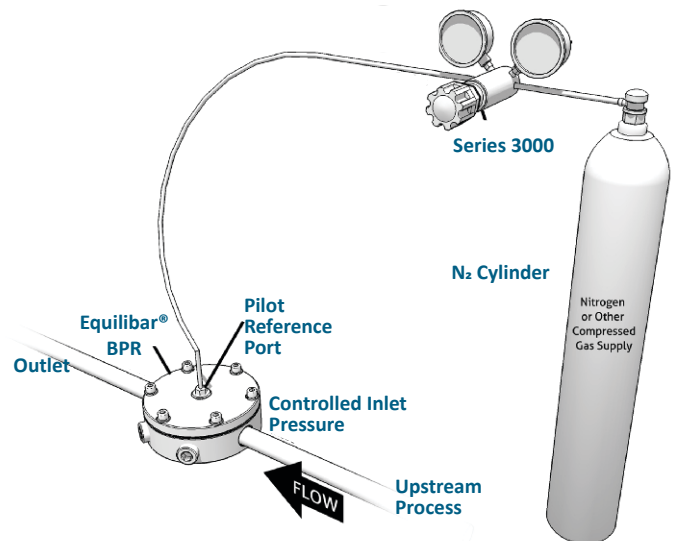

PREPARING FOR INSTALLATION

- Inspect the Series 3000 for any damage and consult Equilibar before proceeding if you find any damage.
- Verify that the part number on the product label matches what you ordered. See next page for product table.
- Refer to the product label for maximum inlet pressures. Never connect the Series 3000 to a supply source having a pressure greater than the maximum rated pressure.
- Ensure the materials of construction of the Series 3000 model you received are compatible with the fluids used. It is the responsibility of the system user to ensure compatibility.
- Clearly establish flow direction of the fluid before installing the regulator. It is the responsibility of the user to install the equipment in the right direction.
- Tapered pipe thread connections will require using a thread sealant. Do not use PTFE tape as loose strands may contaminate the regulator and cause the regulator to leak.

The Series 3000 is **not** a “Safety Accessory” as defined by the Pressure Equipment Directive 2014/68/EU. Be sure to install appropriate over pressure protection devices such as safety relief valves or rupture discs to protect the system from exceeding the maximum allowable working pressures. These safety devices must meet applicable law, codes, regulations, and standards for your jurisdiction.

The Series 3000 is not intended to be used as a shut off device. When not in use, the inlet supply should be turned off.

Series 3000 SS316 High Pressure Reducing Regulator

VERIFICATION

Using the table below, verify the part number on your regulator and confirm pressure and material compatibility with your system. It is the responsibility of the end user to ensure compatibility.

SPECIFICATIONS

PART NUMBER	CAPTURED VENT	MAX INLET PRESSURE PSIG / BAR(G)	OUTLET PRESSURE RANGE PSIG / BAR(G)
31-10082-2100-02-0	Y	10,000 / 689	5 - 250 / 0.35 - 17
31-10082-2110-02-0	Y	10,000 / 689	5 - 500 / 0.35 - 35
31-10082-2120-02-0	Y	10,000 / 689	5 - 1000 / 0.35 - 69
31-10082-2130-02-0	Y	10,000 / 689	10 - 1500 / 0.69 - 103
31-10082-2140-02-0	Y	10,000 / 689	15 - 2500 / 1.0 - 172
31-10082-2150-02-0	Y	10,000 / 689	25 - 4000 / 1.7 - 275
31-10082-2160-02-0	Y	10,000 / 689	50 - 6000 / 3.5 - 414
31-10082-2170-02-0	Y	10,000 / 689	100 - 10,000 / 6.9 - 689.5

MATERIALS OF CONSTRUCTION

REGULATOR PART	MATERIAL
Body (Wetted)	316 Stainless Steel
Bonnet (Non-Wetted)	303 Stainless Steel
Piston (Wetted)	316 Stainless Steel
Seals (Wetted)	Viton®
Backup Rings (Wetted)	PTFE
Valve Seat (Wetted)	Vespe®
Other Parts (Wetted)	316 Stainless Steel

Viton® and Vespe® are registered trademarks of DuPont.

INSTALLATION:

The Series 3000 regulator is shipped ready for use. No adjustments are necessary. The regulator may be mounted in any position without affecting its operation. The unit can be mounted using optional 30-10059 mounting bracket (See Figure 1).

Clean all process lines to remove dirt before installation. It is recommended to install a sintered metal filter with a 40 - 100 micron rating in the process line ahead of the regulator inlet.

The Inlet and Outlet ports are labeled "In" and "Out" (See Figure 2). There are two inlets and two outlets so that gauges may be installed to measure inlet and outlet pressures.

Apply a minimum amount of pipe compound to the male threads of the fitting only. Do Not use Teflon tape as a sealant. Start with the third thread back and work away from the end of the fitting to avoid contaminating the regulator.

Oil-free gas must be used with the regulator.

Tighten all connections securely. Avoid using undersized fittings that will limit the flow through the regulator.

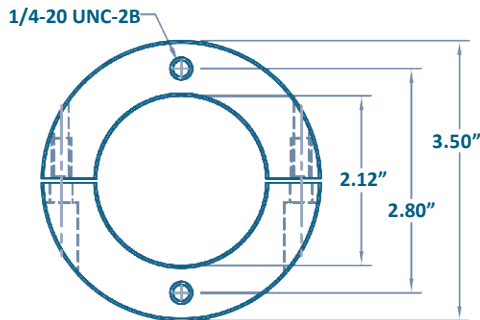

Figure 1: 30-10059 bracket dimensions

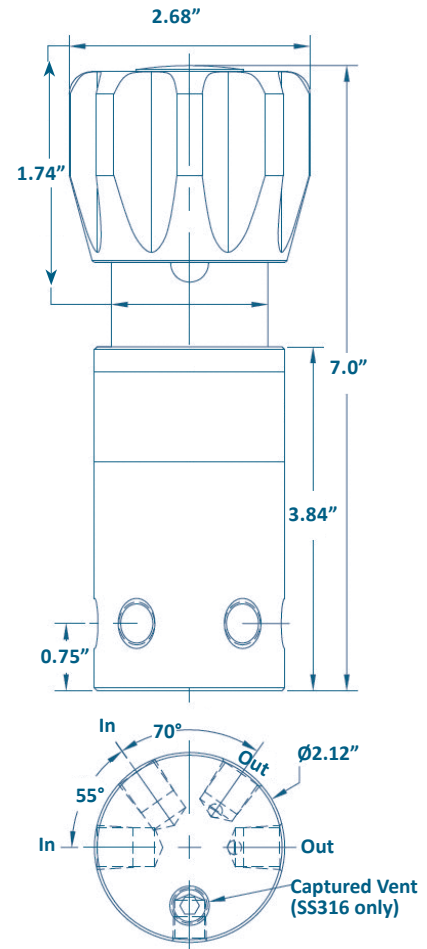

Figure 2: Series 3000 SS316 dimensions

MAINTENANCE

The Series 3000 is a robust device and should work well as received and over a long period of time if the process media is clean and filtered. If you are experiencing trouble with your Series 3000 pressure reducing regulator, please contact Equilibar for assistance.



Series 3000 SS316 Pressure Reducing Regulator

SYSTEM HAZARD ANALYSIS

Both normal operation as well as possible failure modes and foreseeable misuse must be accounted for in the design of the system which interacts with and connects to the Equilibar back pressure regulator (BPR). It is the responsibility of the end user to account for these hazards. **Please read all the following safety and hazard precautions before installing or operating any equipment.**

1. The Series 3000 regulator is not certified as or marketed as a pressure vessel safety relief valve. The Series 3000 is a precision control valve. Guarding against overpressure must be achieved with devices designed and marketed as such.
2. Install a pressure relief device downstream of the regulator to protect the process equipment from overpressure conditions. Shut off the supply pressure when regulator is not in use.
3. Refer to the product label for maximum pressure ratings. Take steps to ensure these values cannot be exceeded. Where necessary to protect equipment, a suitable type of safety overpressure relief valve must be used.
4. Never connect the regulator to a supply source having a pressure greater than the maximum rated pressure of the regulator.
5. Verify the designed pressure rating of all equipment (e.g. supply lines, fittings, connections, filters, etc.) in the system is capable of handling the supply and operating pressure.
6. Ensure the materials of construction of the Series 3000 model you received are compatible with the fluids in the process. It is the responsibility of the end user to ensure compatibility.
7. Inspect the regulator before each use and perform periodic inspection for continued and safe operation. The frequency of inspection depends on the final application and is the responsibility of the end user to determine.
8. It is the responsibility of the end user to use this product in a way that prevents injury to personnel should leakage occur. See Standard Terms and Conditions for important Limitation of Liability notes.
9. If the regulator leaks or malfunctions, take it out of service immediately.
10. Ensure process fluid flow is from the Inlet port (IN) to the Outlet port (OUT).
11. It is recommended to install a sintered metal filter with a 40 to 100 micron rating in the process line before the inlet.
12. The regulator has been carefully designed by skilled engineers to provide proper safety ratios and adequate pressure regulation. Do not modify equipment or add attachments not approved by manufacturer.
13. Apply pressure to the system gradually, avoiding a sudden surge of fluid or pressure shock to the equipment in the system.
14. Do not use the regulator as a structural member. All piping and plumbing connections to the regulator should be adequately supported. The Series 3000 is available with an optional mounting bracket.
15. Read and follow precautions on compressed gas cylinders and labels. Obtain and understand the Safety Data Sheets (SDS) for each fluid used in the system.
16. Enriched oxygen media (>21%) should not be used. Oxygen service requires special expertise and knowledge of system design and material compatibility in order to prevent injury and damage.
17. Be sure that the system media is vented to a safe environment, away from employees, and in accordance with applicable laws in your jurisdiction. Take care that the vent port cannot become blocked during operation by a valve closure, snow, ice, condensate, insects, birds nesting, etc.
18. Even inert gasses can cause suffocation through oxygen displacement. Take care to ensure that adequate ventilation and oxygen levels will be maintained.
19. Never use grease on these regulators. Oil and grease are easily ignited under pressure.
20. Do not bleed the system by loosening fittings.
21. Use proper thread sealants on tapered pipe threads. Do not use PTFE tape, as loose strands will contaminate the regulator and cause the regulator to leak.
22. Assume the external temperature of the regulator will rise or fall to match the temperature of the process media flowing through it. In addition to thermal hazards posed to humans by directly touching the exterior or the regulator, it is the duty of the end user to verify that the temperatures of the process media do not exceed the ignition temperatures of any combustible gases or dust (or mixture) that may be present in the process.
23. Assume the internal temperature of the regulator will rise or fall to match the temperature of the ambient environment. Ensure that the process media flowing through the regulator cannot be damaged or ignited by the maximum and minimum ambient environment temperatures. Low ambient temperatures can cause the media within the regulator to freeze.
24. Prevent icing of the equipment by using low dew point gases.
25. Never perform maintenance or inspections on a system when pressurized fluids are present. De-pressurize the system before performing this work.
26. Component function, adequate ratings, proper installation, operation, and maintenance are the responsibility of the system user.

NOTE: If an air line lubricator is used, it MUST be located downstream of the regulator to avoid interference with performance.

Equilibar's quality system is
ISO 9001:2015 certified.