

Research Series Precision Back Pressure Regulator

REGULATOR USE AND STARTUP

WARNING:

Make sure that you have read and understand these directions before using, installing, or maintaining the Equilibr pressure regulator. Take steps to ensure this instruction manual reaches the operator of this regulator and stays with the regulator throughout its lifetime. Use, installation, operation, and maintenance of all pressurized products including this regulator must be performed by personnel who are properly trained and qualified through experience or specific training.

Failure to properly observe the instructions contained in this document may result in, but is not limited to:

- Serious personal injury or death
- Unconstrained release of the pressurized media
- Permanent damage to the pressure regulator and/or permanent damage to connected equipment



2 SET-POINT OPTIONS

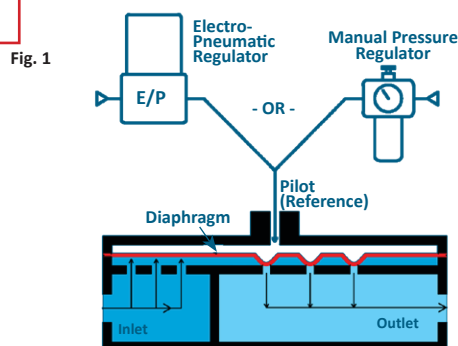

BACKGROUND

The Equilibr® Research Series valves are precision back pressure regulators (BPR's). These BPR's control the fluid pressure at the inlet "I" port. The Equilibr BPR controls the inlet pressure by allowing excess flow to vent from the system through the regulator's outlet "O" port. The flow direction is from inlet to outlet. The Equilibr BPR is pilot operated, where the pressure setpoint is determined by the pressure applied to the "Pilot" or "Reference" port on the BPR (see Fig. 1). The BPR will control the pressure at its inlet port in a precise 1 to 1 relationship with the setpoint pressure applied to the pilot port. The pilot pressure may be applied using a manual pressure regulator or an electronic pressure regulator (electro-pneumatic regulator).

Refer to Fig. 1. The Equilibr BPR uses a flexible membrane diaphragm to both sense the pressure and to provide a direct seal against the orifices in the regulator body. The pilot pressure is applied to one side of the diaphragm. The Inlet "I" port pressure is sensed on the other side of the diaphragm. When the pilot pressure is higher than the Inlet pressure the diaphragm is pushed firmly against the orifices to form a seal and the regulator is effectively closed. When the inlet pressure builds and just equals the pilot pressure, the closing forces are removed from the diaphragm and media can begin to pass from the Inlet to the Outlet port. When sufficient media has passed through the regulator, the Inlet pressure will be reduced slightly, and the diaphragm is allowed to seal against the orifices again. In normal practice equilibrium is achieved and the diaphragm modulates into a position where just enough flow is allowed out of the regulator in order to maintain a steady pressure on the Inlet port. (see Fig. 2)

Typical Circuits: A back pressure regulator is used to control the pressure in a system by venting any excess flow that would otherwise cause the system pressure to increase above the pilot setpoint pressure. In the example circuit shown, the BPR is used to control the outlet pressure of a pump (see Fig. 3). Excess fluid is vented through the BPR back to the fluid reservoir.

Another example application is to use a BPR to control the pressure in a catalyst reactor as various reactants are added (see Fig. 4). The reaction process, the influx of the reactants, and the rise in temperature of the mixture all act together to increase reactor pressure. The Equilibr BPR maintains the reactor pressure at the desired setpoint by venting any media which would otherwise cause the pressure to increase above its setpoint.

Equilibr has trained engineers who can work with you to suggest a regulator design and wetted materials for your specific application. These suggestions are recommendations only and are dependent on complete and accurate information from the end user about the application. It is the ultimate responsibility of the user to determine the compatibility of the media with both the materials of construction of the back pressure regulator and the pilot gas in use.

The diaphragm installed in the back pressure regulator is a careful balance between the pressure, temperature, media compatibility, and flow rate. Often performance in one area must be sacrificed to obtain acceptable performance in another. Many diaphragm types cannot achieve tight shutoff and must have some minimum system flow always present. If the system flow rate into the back pressure regulator is less than the minimum flow rate required by the installed diaphragm, then the system pressure will fall below the target setpoint pressure.

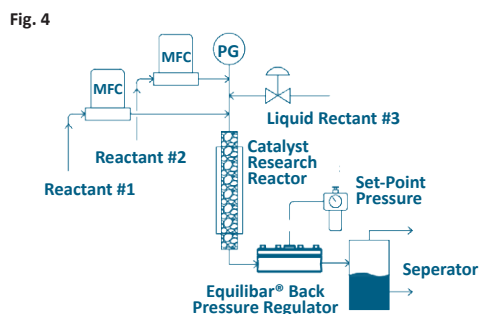
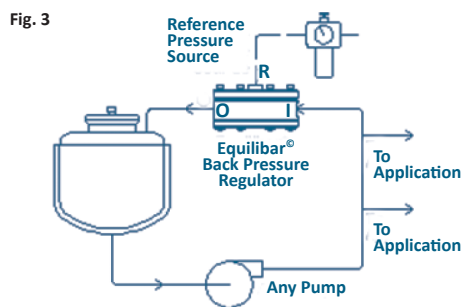
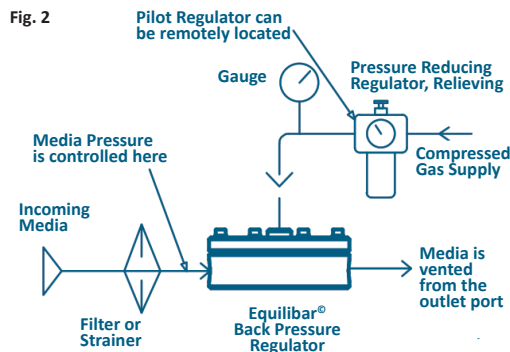

Research Series Precision Back Pressure Regulator

PREPARING FOR INSTALLATION

our Equilibar® back pressure regulator (BPR) arrives assembled, cleaned and ready to install.

- Every Equilibar regulator is individually hand tested at the factory for operation and external leakage. Leak testing is typically performed at 1.5X the MAWP.
- Equilibar regulators are cleaned internally and externally at the factory using aqueous based cleaners in an ultrasonic cleaner and manual wipe down with denatured alcohol.
- A small amount of Krytox™ lubricant is occasionally used on the internal non-wetted O-ring.
- Inspect the Equilibar® BPR for any damage. Consult Equilibar before proceeding if you find any damage.
- Verify that the part number on the Equilibar BPR product label matches what you had requested.
- Verify that the rating on the Equilibar BPR label for maximum allowable working pressure (MAWP) and maximum allowable working temperature (MAWT) will not be exceeded when the BPR is used.
- Many diaphragms are manufactured with a small tab of protruding material. This is nonfunctional and is included only to allow easy inspection of the diaphragm material and thickness without the need to disassemble the regulator.
- Call or e-mail Equilibar if you have any questions, concerns, or need a new copy of these instructions. Be sure to include the full part number and serial number of the BPR you are inquiring about. (+1-828-650-6590, info@equilibar.com)
- The Equilibar BPR is not a “Safety Accessory” as defined by the Pressure Equipment Directive 2014/68/EU. Be sure to install appropriate over pressure protection devices such as safety relief valves or rupture discs to protect the system and the BPR from exceeding the maximum allowable working pressures. These safety devices must meet applicable law, codes, regulations, and standards for your jurisdiction.
- Take precautions to prevent injury to personnel in the event of a diaphragm failure or external leak. Sensitive fluid controls such as the Equilibar BPR can experience internal or external leaks. See standard terms and conditions for important limitations of liability notes
- Diaphragms may fail in the open or closed position. Proper [safety precautions](#) should be taken for either failure mode.
- Inlet ports are stamped with an “I” as shown. Outlet ports are stamped with an “O”.
- In some models, there are ports plugged with pipe plugs which were used during machining operations. They are common with the outlet “O” port and are not typically used. Plugs are sealed with PTFE tape rated to 260C for factory testing. A small amount of Krytox™ lubricant is occasionally used. Please substitute sealant of your choice if using at higher temperatures.
- The inlet “I” port is connected to the point in the system where it is desirable to maintain or control the pressure. The best pressure control will be seen if the plumbing to the BPR inlet port is as short and as large as practical to minimize the amount of pressure drop in the plumbing.
- Install a strainer or filter upstream of the Equilibar BPR where necessary to prevent plugging of the orifices. Recommended 100 micron/100mesh or better. Consider the effect that pressure drop in the filter will have on the pressure control in your system.
- System media will be vented through the BPR outlet “O” port. Be sure that the media is vented to a safe environment, away from employees, and in accordance with applicable laws in your jurisdiction. Take care that the outlet port cannot become blocked during operation by a valve closure, snow,

ice, condensate, insects, birds nesting, etc.

- Even inert gasses can cause suffocation through oxygen displacement. Ensure that adequate ventilation and oxygen levels will be maintained when media is vented from the BPR’s outlet (O) port.
- Provide adequate exhaust line capacity to prevent pressure build-up on the BPR’s outlet (O) port. Short or oversized exhaust lines are recommended.
- Tapered pipe thread connections will require the addition of a sealant. PTFE tape may be used if it is compatible with your process and media. Take care that the PTFE tape does not extend past the first two male threads to prevent tape from being ingested by the regulator. Tape or other debris can prevent the BPR from closing tightly, thereby decreasing precision at low flow rates. PTFE based pipe dope, or an anaerobic “Loctite” product may also be used as a sealant. Confirm that any thread sealant is compatible with your process, temperature, and media.
- Thread sealant should be used on pipe threads of plastic units. Users take caution not to over torque fittings into polymer bodies. This can result in cracking or damage of the unit. Industry standard recommendation is 1/4 turn past hand tight.
- Any bolt, screw, or connector that is threaded into a stainless steel body should have some small amount of lubricant to prevent thread galling. Threads galling together is usually permanent and causes the regulator to be scrapped. The Equilibar factory applies engineering-approved lubricant to all bolt and screw thread connections that are not wetted by the process fluid.

PREPARING THE PILOT REGULATOR

- The pilot pressure medium should be an inert compressible gas. Incompressible media such as liquids do not make effective pilot media because they do not allow the BPR diaphragm to adjust quickly. Make sure the pilot medium is compatible with the media flowing through the BPR.
- The controlled pressure is a near exact 1:1 relationship to the pilot pressure. Many users find that installing a pressure gauge in the pilot port offers advantages over installing a gauge in the Inlet “I” port. The inert pilot media can be read with a less expensive gauge and the pilot pressure may be set even when there is no system media actively flowing.

INSTALLING

1. The Equilibar BPR and pilot regulator arrive ready to use.
2. Install the pilot regulator following instructions included with the order. Check the performance of the pilot regulator before attaching to the pilot port of the Equilibar BPR.
3. The Equilibar BPR is not orientation sensitive and may be mounted in any plane and maintain good pressure control.
4. Ensure that the inlet “I” and outlet “O” are installed in the proper direction of flow. Pressure is controlled at the inlet “I” port.
5. Connect the pilot regulator outlet port to the pilot(reference) port of the BPR and adjust the pressure to the desired setpoint.
6. Equilibar recommends an initial setting of polymer and rubber diaphragms up to 1.5X of application operating pressure. This is achieved by applying pressure to the reference port of the Equilibar. This ‘setting of the diaphragm’ can help the diaphragm perform at lower flow rates. For metal diaphragms, Equilibar recommends applying a set pressure of **only 1X** of operating pressure for best performance. The unit is designed to withstand full differential pressure of rated pressure from reference/pilot to process pressure.

INSTALLING CONTINUED ON NEXT PAGE

Research Series Precision Back Pressure Regulator

INSTALLING (CONTINUED)

- Equilibar recommends that reference pressure always be applied when running the process fluid through the Equilibar, such as in the case of pressure testing a system that has an Equilibar BPR installed. This helps prevent the diaphragm from lifting and deforming into the cap which can have a negative impact on performance.
- The BPR is designed to have maximum pilot pressure applied even when there is no pressurized media at the inlet (I) port. No damage will result.
- Start the flow of process fluid after the pilot pressure has been applied and the diaphragm has been set.
- Exercise caution when reducing the pilot pressure. The BPR will attempt to reduce the inlet pressure at the same rate that the pilot pressure is being reduced. This can result in extremely rapid release of media through the outlet (O) port of the regulator. Reduce the pilot pressure as slowly as practical.
- When preparing for maintenance or shutting the system down, turn the process fluid off before removing pilot pressure supply to the pilot port.

MAINTENANCE NOTES

- Maintain strainer or filter upstream of device to avoid debris getting trapped in the orifices
- Annual inspection of diaphragm integrity is recommended, especially for applications where there is strong or regular pulsing (i.e. reciprocating pump, etc.).
- It is expected that O-rings and diaphragms will need to be replaced on a regular basis, the timing of which is dependent on the application.
- It is recommended to order spare parts prior to performing maintenance. The following replacement part kits are available for order:
 - RBK – Rebuild Kits – replacement parts for O-rings AND diaphragms
 - DI – Diaphragm Kit – replacement parts for diaphragms only
 - OR – O-ring Kit – replacement parts for the O-rings only
- Visit our [maintenance website](https://www.equilibar.com/maintenance) for videos or contact us for more information at www.equilibar.com/contact.

PREPARING FOR MAINTENANCE OR TROUBLESHOOTING

- When shutting the system down for maintenance or troubleshooting, turn the process fluid off before removing pilot pressure supply to the pilot port. This step will prevent a sudden release of system media pressure through the BPR.
- Release the pilot pressure and remove the pilot port piping to clear the BPR for maintenance. Equilibar BPR's can be serviced 'inline' and do not need to be removed from the system piping.
- Loosen the bolts in the cap of the BPR and disassemble wearing proper protective equipment. See exploded views on page 4-5.
- Inspect diaphragm and O-rings for integrity to determine if they need to be replaced. Check for scratched O-ring sealing surfaces.
- Clean all wetted surfaces to remove any residual process fluid and particulates.
- Reassemble the clean parts with new diaphragm and O-rings following the instructions on pages 4-5.

TROUBLESHOOTING

PROBLEM	GUIDANCE
Maximum flow is reduced	Clean out internal orifices
Will not maintain back pressure at low flow rates	<ol style="list-style-type: none">Inspect the regulator for debris or diaphragm damage which prevents the diaphragm from sealing against the orifice in the regulator bodyContact Equilibar application engineer to review low flow specifications
External leak around diaphragm	<ol style="list-style-type: none">Check for loose boltsCheck for misaligned flanges, O-rings or diaphragmCheck for scratched sealing surfaceCheck for O-ring Damage
Chatter on the downstream tubing	<ol style="list-style-type: none">Increase exhaust piping sizeContact factory for additional assistance
Air in process exhaust	Check for ruptured diaphragm
Fluid out of the reference port	Check for ruptured diaphragm
Leaking (not from process ports)	Lubricate and/or stretch O-rings to get better O-ring seal

RATED PRESSURE NOTE

Equilibar regulator bodies have a *Shell pressure rating* based on the body and bolt strength using principles of the ASME B31.3 and confirmed using hydrostatic testing. These *Shell pressure ratings* are the maximum rating for each design as listed in the technical brochures. For example, H3P in SS316L (H3PxS) is listed with a maximum pressure rating of 3000 psig.

Equilibar configures individual regulators to the specific customer application which may involve fitting the valve with a thinner diaphragm to meet precision or low-flow requirements. The diaphragm selection, operating temperature, chemical composition or other factors cause pressure derating. Therefore, the MAWP printed on an Equilibar BPR label reflects that of the selected diaphragm and application conditions but will not exceed the Shell pressure rating of the body design.

The maximum pressure rating for the shell is always based on the body and bolt strength and is **not** printed on the product label. Customers may contact Equilibar engineers if they desire to increase unit MAWP by upgrading diaphragm thickness.

Research Series Precision Back Pressure Regulator

ASSEMBLY INSTRUCTIONS FOR MODELS WITHOUT A REMOVEABLE SEAT

The following instructions are for models without a removeable seat insert: **LF, HF, H3P, H3PF, H6P, H6PF, H10P, U10L, HT, HTF and ULHT**
Assembly instructions for U3L, U6L and ZF are on pg 5

1. Make sure all components are clean and free of any debris.
2. If the bolts and bolt holes were cleaned with chemicals, lubricating the bolts is recommended to prevent the threads galling together.
3. Lay Reference Cap (1) upside down with every other bolt (6) in place. Lock washers (7) are not required.
4. Carefully place O-ring (4) or gasket inside groove of Reference Cap (1). *For all HT models, we recommend adding a light lubrication of petroleum jelly to keep HT Gaskets from moving.*
5. Inspect diaphragm (3) for any damage; replace if there is any question about the condition. Some diaphragm types have a particular side which must face the control orifices. If so, this will be noted in the packaging of the spare diaphragm.
6. Lay diaphragm (3) down, centered onto Reference Cap (1), aligning bolt holes with bolts.
7. Where applicable, insert second O-ring or gasket(5) into groove on body (2). For 8-bolt designs, if O-ring rests on inner groove wall, slight stretching of O-ring to rest on the outer wall is recommended. Legacy units may not have a body O-ring groove. *Light lubrication of HT Gaskets with petroleum jelly is recommended for all HT models.*
8. Invert Body (2) onto diaphragm (3), aligning bolts (6).
9. Lift up reference cap (1) to meet body (2) and hold assembly together while inverting to upright position.
10. Finger tighten all bolts (6).
11. Add remaining bolts (6) and washers (7, if using) and finger tighten.
12. Tighten all bolts using a torque wrench at the recommended setting and tightening in a star pattern as shown in Figure B.

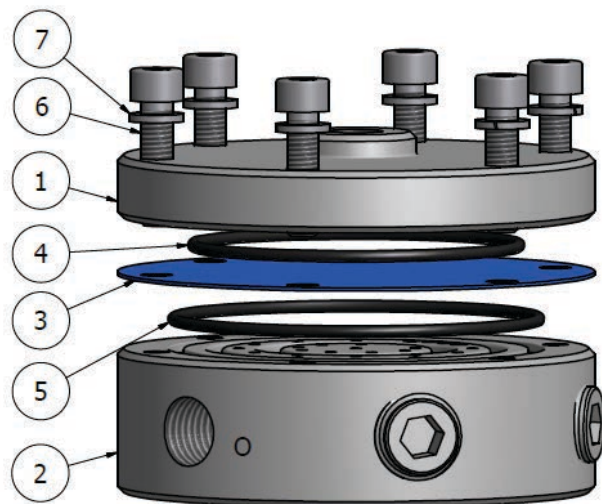

Figure A: Exploded View Standard Model

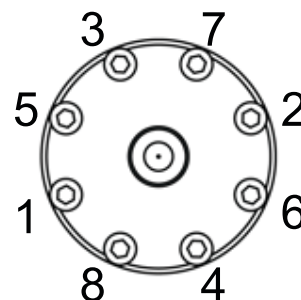

Figure B: Sample Torque Pattern

Recommended torque wrench settings:

Assembly instructions and torque settings for U3L, U6L and ZF on pg 5

MODEL ¹	BOLT ¹	BOLT MATERIAL	RECOMMENDED TORQUE ²
LF, HF	M5	18-8	29-34 in-lbf / 3.3-3.8 N-m
		All but 18-8	45-55 in-lbf / 5-6.3 N-m
H3P, H3PF & Legacy HP	1/4-28	Any Material	65-75 in-lbf / 7.3-8.7 N-m
H6P, H6PF	3/8-24	Any Material	21-35 ft-lbf / 28.5-47.5 N-m
H10P, U10L & Legacy EHP units	7/16 - 20	18-8	300-400 in-lbf / 34-45.2 N-m
		HSA or CS	40-50 ft-lbf / 54.3-67.8 N-m
HT, HTF and ULHT	1/2-20	Any Material	80-90 ft-lbf / 108-122 N-m

¹Consult factory for any models or bolts not listed inquiry@equilibar.com

²Recommended Torques for Lubricated bolts

See Rebuilding an Equilibar Back Pressure Regulator video: [equilibar.com/support/assembly-rebuild-instructions/](https://www.equilibar.com/support/assembly-rebuild-instructions/)

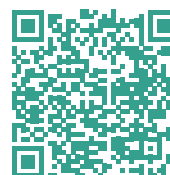

Research Series Precision Back Pressure Regulator

ASSEMBLY INSTRUCTIONS FOR MODELS WITH A REMOVABLE SEAT INSERT

The following instructions are for models with a removable seat insert: **U3L, U6L and ZF**

Assembly instructions for LF, HF, H3P, H3PF, H6P, H6PF, H10P, U10L, HT, HTF and ULHT are on pg 4

Before you begin, it may help to watch the [instructional video on our support page](#)

1. Make sure all components are clean and free of any debris.
2. If the bolt holes and bolts were cleaned with chemicals, it is recommended to lubricate bolts prior to insertion to prevent the threads galling together.
3. Lay Reference Cap (1) upside down with every other bolt inserted (6).
4. Carefully place O-ring (4) inside groove of Reference Cap (1).
5. Place removable seat O-ring (8) on removable seat insert (7).
6. Press removable seat insert and O-ring assembly (7 & 8) into the body (2) with orifice side facing up. Slowly rock removable seat back and forth to prevent O-ring damage/pinch.
7. **ZF units only:** Carefully insert the O-ring support hub (10) into the smaller working O-ring (9). Insert working O-ring and support hub subassembly (9&10) into center recess on the body of the regulator.
8. Inspect diaphragm (3) for any damage; replace if there is any question about the condition. Some diaphragm types have a particular side which must face the control orifices. If so, this will be noted in the packaging of the spare diaphragm.
9. Lay diaphragm (3) down - centered onto Reference Cap (1).
10. Where applicable, insert O-ring into groove on body (2). For 8-bolt designs, if O-ring rests on inner groove wall, slight stretching of O-ring to rest on the outer wall is recommended. This is not required for 6-bolt designs.
11. Invert Body (2) onto diaphragm (3), aligning bolts (6) to bolt holes.
12. Lift up reference cap (1) to meet body (2) and hold assembly together while inverting to upright position.
13. Add remaining bolts (6) and finger tighten.
14. Tighten all bolts using a torque wrench at the recommended setting and tightening in a star pattern as shown in Figure B on page 4.

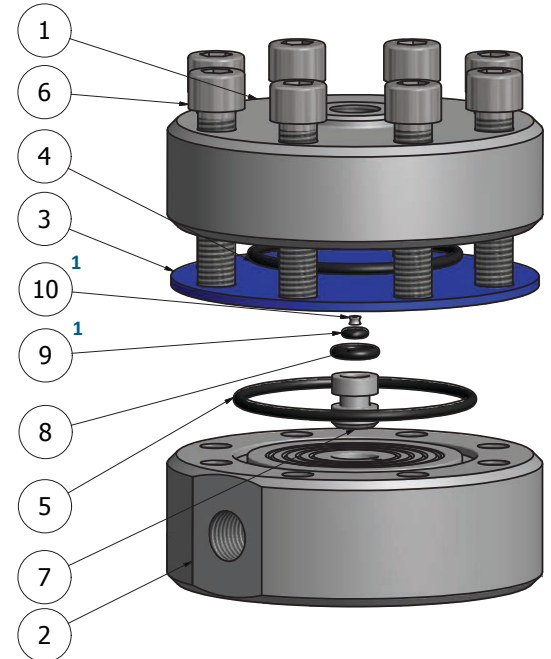

Figure C: Exploded View Removable Seat Insert Model

*The O-Ring and Support Hub sub-assembly are only used in the ZF design.

Recommended torque wrench settings:

MODEL ¹	BOLT ¹	BOLT MATERIAL	RECOMMENDED TORQUE ²
U3L, ZF	1/4-28	Any Material	65-75 in-lbf / 7.3-8.7 N-m
U6L	3/8-24	Any Material	21-35 ft-lbf / 28.5-47.5 N-m

¹Consult factory for any models or bolts not listed, such as custom units: inquiry@equilibar.com

²Recommended Torques for Lubricated bolts

Watch "How to replace an Equilibar removable seat insert": <https://www.youtube.com/watch?v=SaGV1CqjXXU>





Research Series Back Pressure Regulator

SYSTEM HAZARD ANALYSIS

Both normal operation as well as possible failure modes and foreseeable misuse must be accounted for in the design of the system which interacts with and connects to the Equilibar back pressure regulator (BPR). It is the responsibility of the end user to account for these hazards. **Please read all of the following safety and hazard precautions before installing or operating any equipment.**

- a. The BPR is not certified as or marketed as a pressure vessel safety relief valve. The BPR is a precision control valve. Guarding against overpressure must be achieved with devices designed and marketed as such.
- b. Sensitive diaphragms and external seals can leak. It is the responsibility of the end user to use this product in a way that prevents injury to personnel should leakage occur. See Standard Terms and Conditions for important Limitation of Liability notes.
- c. If the internal diaphragm ruptures or leaks, the gas or fluid on the pilot port can be introduced into the process fluid. Make sure that the fluids are compatible and not hazardous when mixed.
- d. If the internal diaphragm ruptures or leaks, process fluid can enter the pilot port plumbing.
 - i. Make sure that the process fluids and the pilot are compatible and not hazardous when mixed. Most auxiliary pressure regulators used to provide pilot pressure to the BPR are of the self-relieving design. Guard against the process fluid relieving out the pilot regulator if the BPR diaphragm fails. One method to accomplish this is to set the pilot pressure into a static volume chamber that is sealed with an ON/OFF valve after the pressure is set to the desired value. Another method is to feed the pilot pressure from the pilot regulator through a check valve to the BPR. In order to reduce the pilot pressure a bleed from the pilot port to a safe location must be employed. In many cases this bleed can be made to the output of the BPR.
 - ii. If an electronic pressure regulator is used then special consideration must be made. In addition to reviewing the prospect of having the process media coming in contact with and venting out of the electronic pressure regulator, the possibility of ignition of the media by the electronic pressure regulator must be examined. It is the users responsibility to determine if a hazardous area classification exist and to make sure that the electronic pressure regulator employed meets or exceeds the requirements of intrinsic safety for that area.
- e. If the internal diaphragm ruptures or leaks the result is often that the BPR will fail into a closed position. This results in a blocked pipe with no path for the fluid to escape through the BPR. Over pressurization of the upstream can occur. Steps must be taken to ensure that the upstream piping is made sufficiently strong to withstand this or is guarded by an overpressure relief device.
- f. Make sure the process pressure to be controlled is connected to the BPR "I" Inlet port. Process fluid flow is from "I" Inlet to the "O" Outlet. If the BPR is connected in reverse it will still operate but it will give poor control and can result in excess pressures.
- g. Observe the maximum temperature and pressure ratings on the BPR label. Take steps to insure these values cannot be exceeded. Where necessary to protect equipment, a suitable type of safety overpressure relief valve must be connected in parallel to the BPR. The overpressure relief valve must be rated to prevent the pressure or temperature from exceeding the BPR maximums as listed on the BPR label.
 - i. In some installations a rupture disc may be substituted for the safety relief valve.
- h. If the discharge piping on the BPR "O" Outlet port becomes blocked, the BPR will open and fill the discharge piping to the same pressure as the maximum pressure in the system. The discharge piping must be rated to contain this pressure or have a safety relief valve to limit this pressure at or below the safe pressure of the discharge piping.
- i. Do not use the BPR as a structural member. All piping and plumbing connections to the BPR should be adequately supported. The BPR series is available with a mounting bracket to facilitate the installation.
- j. Enriched oxygen media (>21%) should not be used in the BPR unless Equilibar has specifically worked with you to provide a product rated and labeled for enriched oxygen. Standard products are not oxygen cleaned. Particle impact, adiabatic compression, and diaphragm motion can all cause ignition in an enriched oxygen media. This kindling chain can cause the entire BPR to oxidize extremely rapidly resulting in high temperatures, discharge of flames and molten metal, and unrestrained escape of process fluid.
- k. The metal cap and body of the BPR are excellent conductors of heat.
 - i. Assume the external temperature of the BPR will rise or fall to match the temperature of the process media flowing through it. In addition to thermal hazards posed to humans by directly touching the BPR exterior, it is the duty of the end user to verify that the temperatures of the process media do not exceed the ignition temperatures of any combustible gases or dust (or mixture) that may be present local to the BPR.
 - ii. Assume the internal temperature of the BPR will rise or fall to match the temperature of the ambient environment. Ensure that the process media flowing through the BPR cannot be damaged or ignited by the maximum and minimum ambient environment temperatures. Low ambient temperatures can cause the media within the regulator to freeze. Expansion cooling in certain gasses can also cause freezing. Freezing can block the BPR and cause excess pressures to build on the "I", Inlet, port. Expansion of water due to freezing can damage the regulator. Ice formation from freezing can perforate metallic foil diaphragms.
- m. The BPR has been carefully designed by skilled engineers to provide proper safety ratios and adequate pressure regulation. Do not attempt to modify the BPR in any way, including adding or enlarging orifices or ports or replacing bolts (cap screws). Only replace the internal O-rings or diaphragms with Equilibar factory provided repair parts.
- n. Never perform maintenance or inspections on a system when pressurized fluids are present. De-pressurize the system before performing this work. De-pressurize inlet pressure before reference otherwise a quick drop in reference pressure can lead to a violent exhaust of the upstream pressure through the regulator.

PATENT INFORMATION

www.equiblar.com/support/patents/

Equilibar's quality system is
ISO 9001:2015 certified.