

QBS Electronic Pressure Regulator

INSTALLATION AND MAINTENANCE INSTRUCTIONS

DESCRIPTION / IDENTIFICATION

The QBS 'stainless steel' series is an electronically controlled pressure regulator. The QBS controls the pressure on its output port proportional to an electrical command signal input.

The QBS is a complete closed loop system consisting of two solenoid valves, a stainless steel pressure transducer, electronic control circuit, a connecting manifold, and a protective IP65 rated housing. Pressure is controlled by the use of two solenoid valves. One valve functions as inlet control, the other as exhaust. The pressure output is measured by the internal pressure transducer and provides a feedback signal to the electronic control circuit. This transducer feedback signal is compared with the command signal input. A difference between the two signals causes one of the solenoid valves to open. The inlet solenoid valve is energized to allow compressed supply gas to flow into the system and increase the controlled pressure. The exhaust solenoid is energized to allow excess gas to escape from the system to atmosphere and lower the pressure. When the difference between the command and the internal pressure sensor signal is within the allowable deadband, both solenoid valves close and flow in or out of the system stops.

A pressure monitor output signal is provided to allow the system pressure to be measured. All QBS electronic pressure regulators come standard with an analog voltage monitor output. A 4-20mA signal is available optionally. This pressure monitor output is an amplified signal from the internal pressure transducer.

The QBS is a relatively low flow regulator. This makes the QBS a great choice any time low flow rates or small volumes require precise pressure control. The QBS is often used to provide the pilot pressure signal to the dome of either an Equilibar® back pressure regulator or an Equilibar vacuum regulator. The QBS can then be used to electronically control back pressure or vacuum pressure in line sizes from 1/8 inch through 6 inch by pilot operating the appropriately sized regulator.



SPECIFICATIONS

ELECTRICAL	
SUPPLY VOLTAGE	15-24 VDC
SUPPLY CURRENT	250mA required
COMMAND SIGNAL	
VOLTAGE	0-10 VDC single ended
CURRENT	4-20 mA differential
COMMAND SIGNAL IMPEDANCE	
VOLTAGE	4.75 K Ω
CURRENT	100 Ω
ANALOG MONITOR SIGNAL	
VOLTAGE	0-10 VDC @ 20mA max
CURRENT	4 - 20 mA Sourcing
PNEUMATIC	
PRESSURE RANGES	Full vacuum - 500 psig 760 mmHg (vac) - 34 bar(g)
OUTPUT PRESSURE ¹	0-100% of range
FLOW RATE	1.2 SCFM @ 100 psig inlet 34 LPM @ 6.9 bar(g)
Cv CAPACITY	0.04
Min CLOSED END VOLUME	2 in ³
PORT SIZE	1/8" NPT; BSPP optional
FILTRATION RECOMMENDED	20 micron nominal (included)
LINEARITY/HYSTERESIS	< \pm 0.2% F.S. BFSL
REPEATABILITY	< \pm 0.05% F.S.
ACCURACY	< \pm 0.5% F.S.
WETTED PARTS ²	Elastomers - Fluorocarbon Manifold - Stainless Steel or Aluminum Valves - Nickel Plated Brass P.Transducer - Stainless Steel
PHYSICAL	
OPERATING TEMPERATURE	32-158°F [0-70°C]
WEIGHT	1.4 lb [0.64 Kg]
PROTECTION RATING	NEMA 4 / IP65
HOUSING	Anodized Aluminum

¹ Pressure ranges are customer specified.

² Others available

QBS Electronic Pressure Regulator

INSTALLATION OF POSITIVE PRESSURE UNITS

1. Apply a small amount of anaerobic sealant (provided) to the male threads of the FPP1 in-line filter supplied with QBS.
2. Install the FPP1 in-line filter into the inlet port labeled 'I' on QBS valve.
3. Connect supply pressure to the FPP1 in-line filter port. See TABLE 1 for maximum inlet pressure ratings. Supply gas must be air or inert gas only and within the limits specified in TABLE 1.
4. Connect the controlled output pressure port labeled 'O' on QBS valve to the system or device where it is desired to regulate the pressure. Note there are two ports labeled 'O', one on the side and one on the bottom. You may use either or both ports. Block any unused 'O' port with a pipe plug.
5. **NOTE:** Too small of a volume connected to the outlet 'O' port may cause the QBS to be unstable and oscillate. A 'motorboat' sound will be heard continuously as the exhaust solenoid intermittently vents compressed gas out the exhaust 'E' port. A length of tubing providing 2 cubic inches of volume or more is recommended on the QBS outlet port to prevent instability. See figure 1.
6. The QBS valve can be mounted in any orientation without affecting performance. Mounting bracket QBT-01 (ordered separately) can be used to attach the QBS valve to a panel or wall surface.
7. Proceed with electrical connections.

CAUTION: USE ONLY ANAEROBIC THREAD SEALANT PROVIDED. OTHER SEALANTS SUCH AS PTFE TAPE AND PIPE DOPE CAN MIGRATE INTO THE INTERNAL SOLENOID VALVES CAUSING BLOCKAGES AND FAILURES.

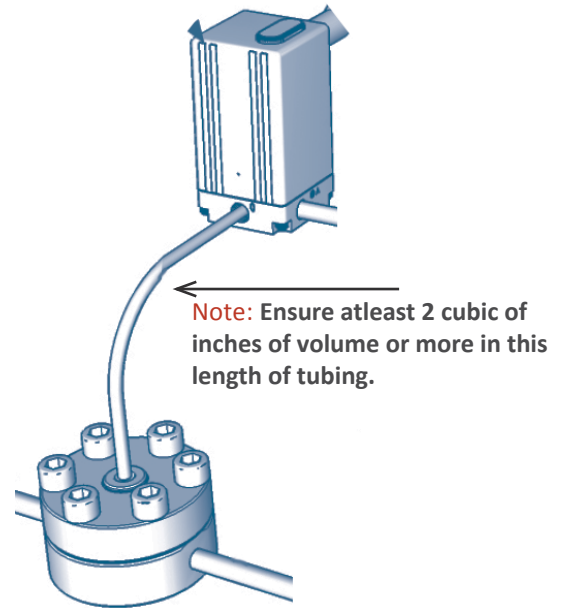

Fig. 1 QBS Electronic Pressure Regulator connected to an Equilibar back pressure regulator providing pilot setpoint pressure.

INSTALLATION OF VACUUM THRU POSITIVE PRESSURE UNITS

The QBS can be custom ordered calibrated to control vacuum thru positive pressure.

1. Connections are the same as the positive pressure instructions above **except the exhaust 'E' port must be connected to a vacuum supply source.**

Be sure that the vacuum supply has an adequate flow capacity to relieve all the pressurized gas that the QBS will vent from the system volume on the controlled pressure port. Otherwise high pressure gas may build on the exhaust port.

TABLE 1

RATED INLET PRESSURE FOR STANDARD QBS VALVES	
For valves ordered with MAX calibrated pressure	MAX Inlet Pressure
Vacuum up to 10 psig (0.69 bar(g))	Consult Factory
10.1 up to 30 psig (0.70 up to 2 bar(g))	35 psig (2.4 bar(g))
31 up to 100 psig (2.1 up to 7 bar(g))	110 psig (7.6 bar(g))
101 up to 175 psig (7 up to 12 bar(g))	190 psig (13 bar(g))
176 up to 300 psig (12.1 up to 20.7 bar(g))	330 psig (22.8 bar(g))
301 up to 500 psig (20.8 up to 34.5 bar(g))	550 psig (37.9 bar(g))

QBS Electronic Pressure Regulator

ELECTRICAL CONNECTIONS

1. Make sure all electrical power is OFF while making electrical connections. Improper connections can damage the QBS
2. Identify the command input and analog output signal types for your specific QBS part number using the ordering information section on the last page of this document. Confirm this against the calibration card included in the packaging.
3. Use the information below to wire the QBS according to your specific part number and signal type(s).
4. Depending on your setup, some wires in the QBT may not be used.

NOTE: ALL COLOR CODES RELATE TO THE FACTORY WIRED QBT POWER CORD.

COMMAND SIGNAL CONFIGURATIONS

VOLTAGE COMMAND VALVES

All voltage command QBS valves use single ended voltage, meaning the DC Common pin (Pin 1) is the common reference for both power and command. The following diagram shows the proper connections.

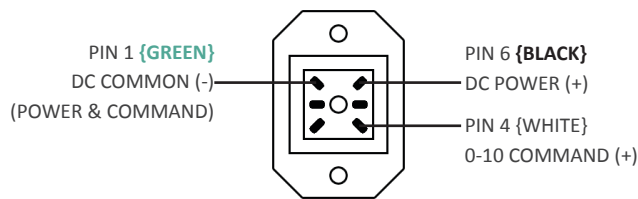

CURRENT COMMAND VALVES

All current command QBS valves use a differential current loop scheme (not isolated), meaning current flow is from Pin 4 to Pin 2 on the QB valve. Some applications may require the common of the power supply that provides loop power for the 4-20mA command to be tied to DC common (Pin 1).

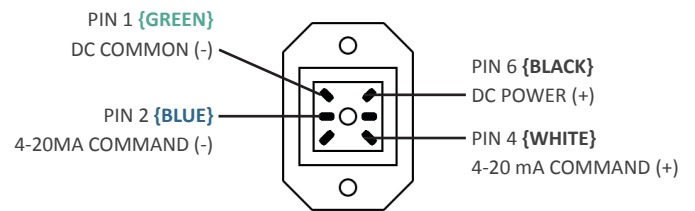

MONITOR SIGNAL CONFIGURATIONS

CURRENT SOURCING MONITOR

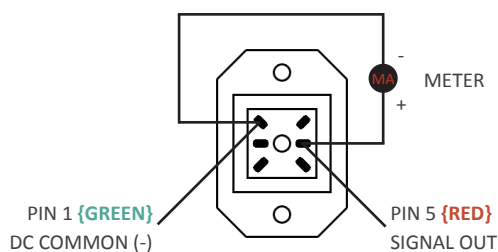

VOLTAGE MONITOR

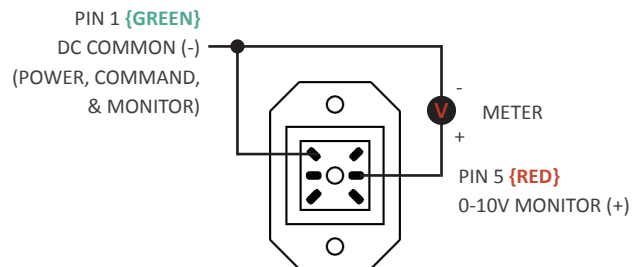

QBS Electronic Pressure Regulator

RECALIBRATION PROCEDURE

All QBS control valves come calibrated from the factory by trained personnel using precision calibration equipment. The QBS valve is a closed loop control valve using a precision electronic pressure sensor. Typical drift is less than 1% over the life of the product. If your QBS valve appears to be out of calibration by more than 1%,

it is not likely to be the QBS. Check the system for adequate supply pressure, wiring and electronic signal levels. Verify the accuracy of your measuring equipment before recalibrating. Consult factory if you have any questions or require assistance. If the QBS valve needs recalibration, use the procedure described below.

1. Identify the inputs and outputs of the valve using the model number of the valve, calibration card included with the valve, and the information provided in this sheet.
2. Connect a precision measuring gage or pressure transducer to the OUT port of the QBS. **Note:** There **must be** a closed volume of at least 2 in³ (34cc) between the valve outlet and the measuring device for the valve to be stable.
3. Connect the correct supply source to the IN port of the QBS, making sure the pressure does not exceed the rating for the valve (See Table 1).
4. Locate the plastic calibration access cap on top of the QBS valve and completely remove it. Located underneath are two adjustment trimpots, Zero "Z" and Span "S". See **Figure 1** for pots location.
5. **NOTE:** Only use this step if your device is totally out of calibration. If it is slightly out of calibration, omit this step and move on to paragraph 6. Using a small screwdriver, turn both the Z and S trimpots 15 turns clockwise. Then turn both the Z and S trimpots 7 turns counterclockwise. This will put the QBS roughly at midscale.
6. Make correct electrical connections as noted. Make sure there is a proper meter in place to measure the command input to the QBS.
7. Set the electrical command input to 100% value.
8. Adjust the SPAN pot until 100% desired pressure is reached (clockwise increases pressure).
9. Set the electrical command input to 10% value.
10. Adjust the ZERO pot until 10% desired pressure is reached (clockwise increases pressure).
11. Repeat ZERO and SPAN adjustments (Step 7 - 10), which interact slightly, until QBS valve is calibrated back to proper range.
12. If at any time during the calibration procedure the QBS control valve oscillates or becomes unstable for more than one second, turn the HYSTERESIS potentiometer (see **FIGURE 1**) counter-clockwise until the oscillation stops, then turn it one more complete turn (in the same direction).
13. Replace calibration access cap.

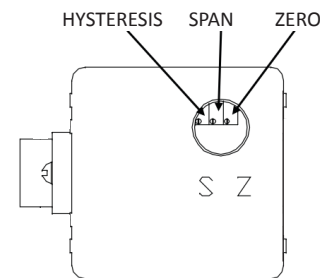
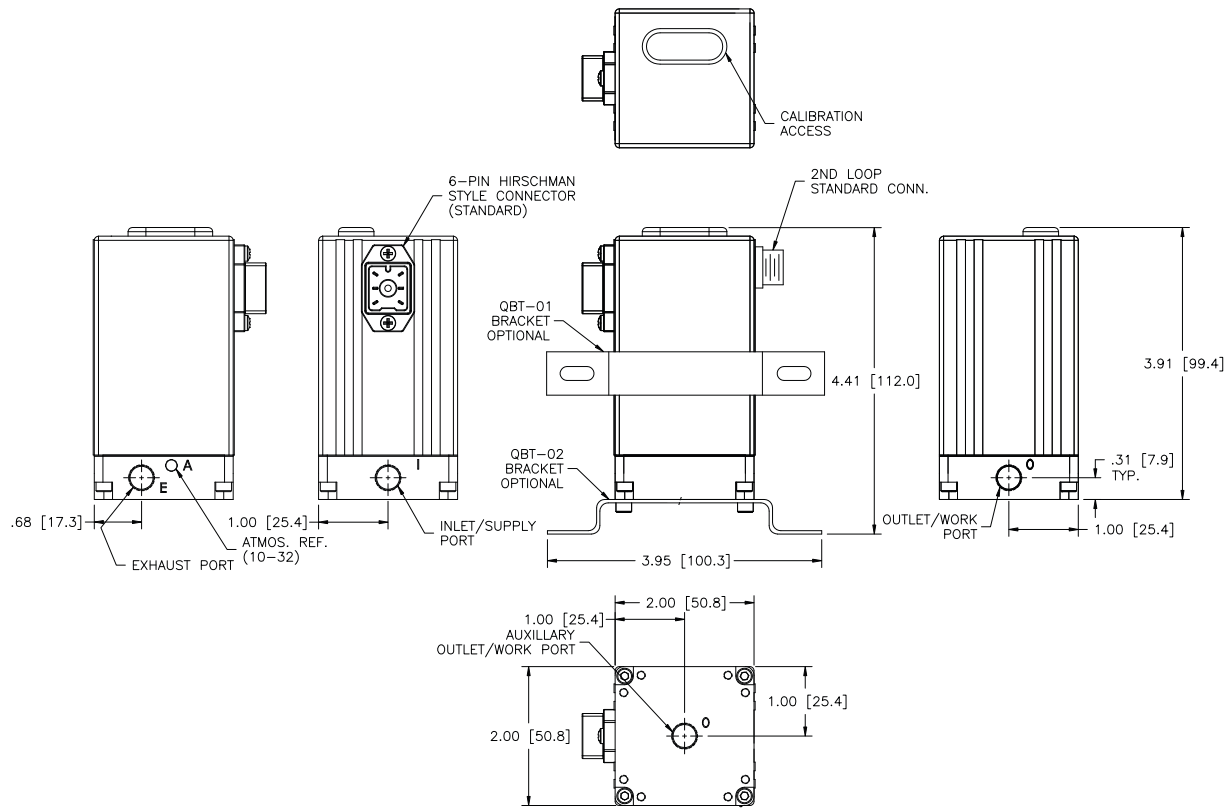

FIGURE 1

QBS Electronic Pressure Regulator

DIMENSIONAL DRAWINGS: INCHES (MM)



MOUNTING BRACKET

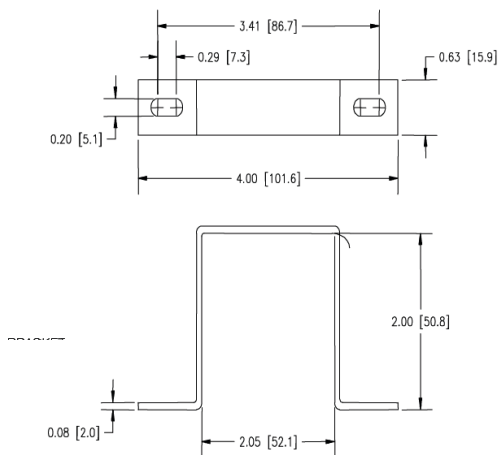

QBT-01 Mounting Bracket

WARNING: Installation and use of this product should be under the supervision and control of properly qualified personnel in order to avoid the risk of injury or death.

QBS Part Configuration

EXAMPLE PART NUMBER	QB	1	SS	E	E	Z		P	0	P	500	PSI	G
Your Part Number:	QB												
		1	2	3	4	5		6	7	8	9	10	11

1 TYPE

- 1 Single Loop

2 MANIFOLD MATERIAL

- SS 303 Stainless Steel
- SA Anodized Aluminum

3 THREAD TYPE

- N NPT (Standard)
- P BSPP

4 INPUT SIGNAL RANGE

- E 0 to 10 Vdc (Single Ended)
- I 4 to 20 mADC (Differential)
- K 0 to 5 Vdc
- V 1 to 5 Vdc*

*Requires V for MONITOR SIGNAL RANGE

5 MONITOR SIGNAL RANGE

- X No Monitor
- E 0 to 10 Vdc
- K 0 to 5 Vdc*
- V 1 to 5 Vdc **
- S 4 to 20 mA

*Requires E, I, or K for INPUT SIGNAL RANGE

** Requires V for INPUT SIGNAL RANGE

6 ZERO OFFSET

- N 0% Pressure Starts Below Atmosphere
- P 0% Pressure Starts Above Atmosphere
- Z 0% Pressure Starts at Zero (Typical)

7 ZERO OFFSET PRESSURE

Typical is 0* - If Greater than 30% of Full Scale Pressure (#9 below) Please Consult Factory.

*If Z for ZERO OFFSET (#6), please leave blank

8 FULL SCALE PRESSURE TYPE

- P 100% Pressure Ends Above Atmosphere

9 FULL SCALE PRESSURE

Must be less than or equal to 500 psig

*For maximum pressures less than 150 psig the QPV series may offer higher performance at lower cost

10 PRESSURE UNIT

- | | | | |
|----|------------|----|------------------------------|
| PS | PSI | IH | Inches Hg |
| MB | Millibars | IW | Inches H ₂ O |
| BR | Bar | MW | mm H ₂ O |
| KP | Kilopascal | KG | Kilograms/cm ² |
| MP | Megapascal | TR | Torr* |
| MH | mm Hg | CW | Centimeters H ₂ O |

*Requires A for PRESSURE UNIT OF MEASURE

11 PRESSURE UNIT OF MEASURE

- A Absolute Pressure
- G Gauge Pressure

Please Consult Factory For More Options And Application Assistance

ACCESSORIES

- QBT-C-6 6 ft. Power Cable
- QBT-01 Wrap-Around Bracket
- QBT-02 Foot-Mount Bracket

TYPICALLY IN STOCK PARTS: (for quick delivery)

PART NUMBER	TYPE	MANIFOLD MATERIAL	CONNECTION	INPUT SIGNAL RANGE	MONITOR SIGNAL RANGE	FULL SCALE PRESSURE	TYPICAL AVAILABILITY
QB1SSNEEZP300PSG	Single Loop	Stainless Steel	1/8" NPT	0-10 Vdc	0-10 Vdc	0-300 psig / 20 bar(g)	1-2 Days
QB1SSNEEZP500PSG	Single Loop	Stainless Steel	1/8" NPT	0-10 Vdc	0-10 Vdc	0-500 psig / 35 bar(g)	1-2 Days
QB1SSNISZP300PSG	Single Loop	Stainless Steel	1/8" NPT	4-20 mA	4-20 mA	0-300 psig / 20 bar(g)	1-2 Days
QB1SSNISZP500PSG	Single Loop	Stainless Steel	1/8" NPT	4-20 mA	4-20 mA	0-500 psig / 35 bar(g)	1-2 Days



Please read all of the following Safety Precautions before installing or operating any Equilibar, Inc. equipment or accessories. To confirm safety, be sure to observe 'ISO 4414: Pneumatic Fluid Power - General rules relating to systems' and other safety practices. Improper operation could result in serious injury to persons or loss of life!

1. OVERPRESSURIZATION

The QBS electronic pressure regulator is not a safety device and must not be relied upon to prevent dangerously high pressures. Where danger from overpressurization exists then an additional valve that is designed and marketed as a safety pressure relief valve must be used to protect the QBS against excess supply pressure and to protect the system should the QBS produce excess pressure on its outlet.

2. PRODUCT COMPATIBILITY

Equilibar, Inc. products and accessories are for use in industrial pneumatic applications with compressed air media or compressed inert (bottled) gas. The compatibility of the equipment is the responsibility of the end user. Product performance and safety are the responsibility of the person who determined the compatibility of the system. Also, this person is responsible for continuously reviewing the suitability of the products specified for the system, referencing the latest catalog, installation manual, Safety Precautions and all materials related to the product.

3. EMERGENCY SHUTOFF

Equilibar, Inc. products cannot be used as an emergency shutoff. A redundant safety system should be installed in the system to prevent serious injury or loss of life.

4. EXPLOSIVE ATMOSPHERES

The QBS Series should not be used where harmful, corrosive or explosive materials or gases are present. Unless specifically certified and labeled, Equilibar, Inc. products cannot be used with flammable gases or in hazardous environments.

5. COMPRESSED GAS QUALITY

Clean, dry air is not required for Equilibar, Inc. products. However, a 40 micron particulate filter is recommended to prevent solid contamination from entering the product. Only neutral gases should be used.

6. TEMPERATURE

Products should be used with a media and ambient environment inside of the specified temperature range of 32°F to 158°F. Consult factory for expanded temperature ranges.

7. OPERATION

Only trained and certified personnel should operate electronic and pneumatic machinery and equipment. Electronics and pneumatics are very dangerous when handled incorrectly. All industry standard safety guidelines should be observed.

8. SERVICE AND MAINTENANCE

Service and maintenance of machinery and equipment should only be handled by trained and experienced operators. Inspection should only be performed after safety has been confirmed. Ensure all supply pressure has been exhausted and residual energy (compressed gas, springs, gravity, etc.) has been released in the entire system prior to removing equipment for service or maintenance. Be sure to employ lock out / tag out procedures.

WARNING

Improper operation could result in serious injury to persons or damages to equipment!

1. PNEUMATIC CONNECTION

All pipes, pneumatic hose and tubing should be free of all contamination, debris and chips prior to installation. Flush pipes with compressed air to remove any loose particles.

2. THREAD SEALANT

To prevent product contamination, thread tape is not recommended. Instead, a non-migrating thread sealant is recommended for installation. Apply sealant two threads from the end of the pipe thread to prevent contamination.

3. ELECTRICAL CONNECTION

To prevent electronic damage, all electrical specifications should be reviewed and all electrical connections should be verified prior to operation.