

FDO4 Sanitary Precision Back Pressure Regulator

REGULATOR USE AND STARTUP

WARNING:

Make sure that you have read and understand these directions before using, installing, or maintaining the Equilibr pressure regulator. Take steps to ensure this instruction manual reaches the operator of this regulator and stays with the regulator throughout its lifetime. Use, installation, operation, and maintenance of all pressurized products including this regulator must be performed by personnel who are properly trained and qualified through experience or specific training.

Failure to properly observe the instructions contained in this document may result in, but is not limited to:

- Serious personal injury or death
- Unconstrained release of the pressurized media
- Permanent damage to the pressure regulator and/or permanent damage to connected equipment



2 SET-POINT OPTIONS

Fig. 1

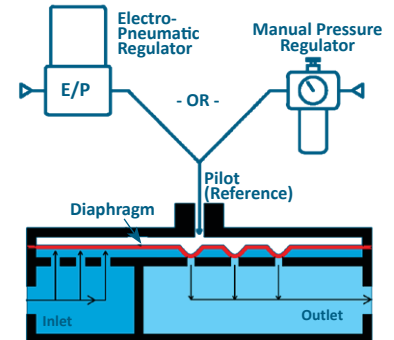

BACKGROUND

The Equilibr® FDO Series are precision back pressure regulators (BPRs). These BPRs control the fluid pressure that is on the inlet “I” port. The Equilibr controls the pressure by allowing excess flow to vent the system through the regulators outlet “O” port. The flow direction is from inlet to outlet. The Equilibr is pilot operated. The pressure setpoint is determined by the pilot pressure that is applied to the “R” reference (also known as pilot or dome) port. The BPR will control the pressure on its inlet port in a precise 1 to 1 relationship with the pressure applied to the pilot port. The pilot pressure may be applied with a mechanical knob adjusted regulator or with an electronic pressure regulator (see Fig. 1).

The Equilibr® BPR uses a flexible membrane diaphragm to both sense the pressure and to provide a direct seal against the orifices in the regulator body. The pilot pressure is applied to one side of the diaphragm. The Inlet “I” port pressure is sensed on the other side of the diaphragm. When the pilot pressure is higher than the Inlet pressure the diaphragm is pushed firmly against the orifices to form a seal and the regulator is effectively closed. When the inlet pressure builds and just equals the pilot pressure, the closing forces are removed from the diaphragm and media can begin to pass from the Inlet to the Outlet port. When sufficient media has passed through the regulator, the Inlet pressure will be reduced slightly and the diaphragm is allowed to seal against the orifices again. In normal practice equilibrium is achieved and the diaphragm modulates into a position where just enough flow is allowed out of the regulator in order to maintain a steady pressure on the inlet port (see Fig. 2)

Typical Circuits:

A back pressure regulator can be used to control the pressure in a delivery system by venting any excess flow that would otherwise cause the system pressure to increase. In the example circuit shown in Fig. 3, a BPR is used to control the outlet pressure of a pump. Excess fluid is vented through the BPR back to the fluid storage tank.

A back pressure valve is sometimes used to prevent bubbles in flow instruments. Accurate flow measurements are not possible with Coriolis flow meters when bubbles are present. When bubbles pass through the sense tube of the mass flow meter, the resulting flow signal can be significantly disturbed. One common method to minimize or prevent bubble evolution is to increase the pressure at the outlet of the Coriolis meter (see Fig. 4). By installing a back pressure regulator downstream of the instrument, gases are more likely to remain in solution and the volume of small bubbles is minimized, thereby improving flow meter accuracy. Equilibr back pressure regulators use a simple diaphragm design and are compatible with many demanding processes, such as sanitary and highly corrosive applications.

Equilibr has trained engineers who can work with you to suggest a regulator design and wetted materials for your specific application. These suggestions are recommendations only and are dependent on complete and accurate information from the end user about the application.

It is the ultimate responsibility of the user to determine the compatibility of the media with the materials of construction of the back pressure regulator and with the pilot gas in use.

The diaphragm installed in the back pressure regulator is a careful balance between the pressure, temperature, media compatibility, and flow rate. Often performance in one area must be sacrificed in order to obtain acceptable performance in another. Many diaphragm types cannot achieve tight shutoff and must have some minimum system flow always present. If the system flow rate into the back pressure regulator is less than the minimum flow rate required by the installed diaphragm, then the system pressure will fall below the target set point pressure.

Fig. 2

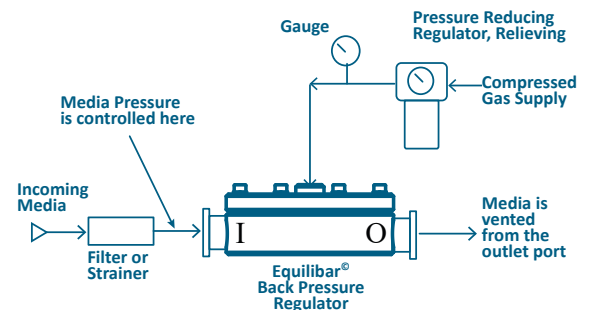

Fig. 3

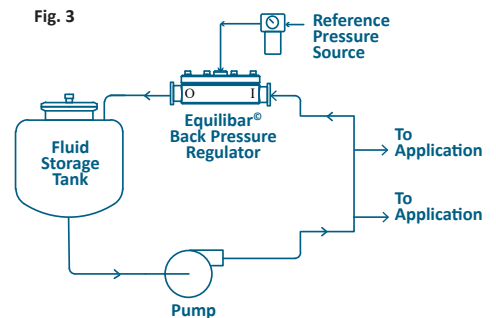
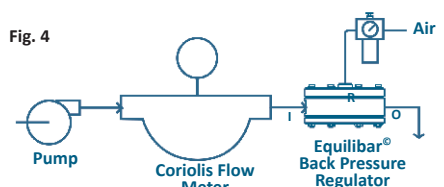

Fig. 4



FDO4 Sanitary Precision Back Pressure Regulator

PREPARING FOR INSTALLATION

1. Inspect the Equilibar BPR for any damage. Consult Equilibar before proceeding if you find any damage.
2. Verify that the part number on the Equilibar BPR product label matches what you had requested
3. Verify that the rating on the Equilibar BPR label for maximum allowable working pressure (MAWP) and maximum allowable working temperature (MAWT) will not be exceeded when the BPR is used.
4. Call or e-mail Equilibar if you have any questions, concerns, or need a new copy of these instructions. Be sure to include the full part number and serial number of the BPR you are inquiring about. (01-828.650.6590, info@equilibar.com)
5. Take precautions to prevent injury to personnel in the event of a diaphragm failure or external leak. Sensitive fluid controls can experience internal or external leaks. See standard terms and conditions for important limitations of liability notes.
6. Diaphragms may fail in the open or closed position. Proper safety precautions should be taken for either failure mode.
7. moved down below
8. Every Equilibar regulator is individually hand tested at the factory for operation and external leakage. Leak testing is typically performed at 1.5X the MAWP.
9. The Equilibar BPR is not a "Safety Accessory" as defined by the Pressure Equipment Directive 2014/68/EU. Be sure to install appropriate over pressure protection devices such as safety relief valves or rupture discs to protect the system and the BPR from exceeding the maximum allowable working pressures. These safety devices must meet applicable law, codes, regulations, and standards for your jurisdiction.
10. Equilibar regulators are cleaned internally and externally at the factory using aqueous based cleaners in an ultrasonic cleaner and manual wipe down with denatured alcohol.
11. Install a strainer or filter upstream of the Equilibar back pressure regulator where necessary to prevent plugging of the orifices. Recommended 100 micron/100mesh or better.
12. Inlet ports are stamped with an "I"; Outlet ports are stamped with an "O".
13. The inlet "I" port is connected to the point in the system where it is desirable to maintain or control the pressure. The best pressure control will be seen if the plumbing to the BPR inlet port is as short and as large as practical to minimize the amount of pressure drop in the plumbing.
14. System media will be vented out the BPR outlet "O" vent port, also called an exhaust port. Be sure that the media is vented to a safe environment, away from employees, and in accordance with applicable laws in your jurisdiction. Take care that the outlet port cannot become blocked during operation by a valve closure, snow, ice, condensate, insects, birds nesting, etc.
15. Even inert gasses can cause suffocation through oxygen displacement. Take care to ensure that adequate ventilation and oxygen levels will be maintained.
16. Provide adequate exhaust line capacity. Short or oversized exhaust lines are recommended.
17. Any bolt, screw, or connector that is threaded into a stainless steel body should have some small amount of lubricant to prevent thread galling. Threads galling together is usually permanent and causes the regulator to be scrapped. The Equilibar factory applies Krytox™ FDA, NSF H1 Food Grade Lubricant to bolt thread connections that are not wetted by the process fluid.

PREPARING THE PILOT REGULATOR

18. The pilot pressure should be an inert compressible gas. Incompressible media such as liquids do not make effective pilot pressures because they do not allow the BPR diaphragm to adjust quickly. Make sure the pilot media is compatible with the media flowing through the BPR.
19. The pilot pressure is a nearly exact 1:1 relationship to the pressure being controlled. Many users find that installing a pressure gauge in the pilot port offers advantages over installing a gauge in the Inlet "I" port. The inert pilot media can be read with a less expensive gauge and the pilot pressure may be set even when there is no system media actively flowing.

INSTALLING

1. The Equilibar BPR and pilot regulator arrive ready to use.
2. Install the pilot regulator following instructions included with the order. Check the performance of the pilot regulator before attaching to the pilot port of the Equilibar BPR.
3. The Equilibar BPR is not orientation sensitive and may be mounted in any plane and maintain good pressure control. Media draining or other considerations may need to be taken in to account by your specific application requirements.
4. Install the BPR ensuring the inlet "I" and outlet "O" are installed in the proper direction of flow.
5. Connect the pilot regulator outlet to the pilot port of the BPR and adjust the pressure to the desired setpoint.
6. Equilibar recommends an initial 'setting' of diaphragms at application operating pressure. This is achieved by applying that pressure to the reference port of the Equilibar. This 'setting of the diaphragm' can help the diaphragm perform at lower flow rates.
7. Equilibar recommends that reference pressure always be applied when running the process fluid through the Equilibar, such as in the case of pressure testing a system that has an Equilibar BPR installed. This helps prevent the diaphragm from lifting and deforming into the cap which can have a negative impact on performance.
8. The BPR is designed to have maximum pilot pressure applied even when there is no pressurized media at the inlet (I) port. No damage will result.
9. Start the flow of process fluid after the pilot pressure has been applied and the diaphragm has been set.
10. Exercise caution when reducing the pilot pressure. The BPR will attempt to reduce the inlet pressure at the same rate that the pilot pressure is being reduced. This can result in extremely rapid release of media through the outlet (O) port of the regulator. Reduce the pilot pressure as slowly as practical.
11. When preparing for maintenance or shutting the system down, turn the process fluid off before removing pilot pressure supply to the pilot port.

FDO4 Sanitary Precision Back Pressure Regulator

MAINTENANCE NOTES

- Maintain strainer or filter upstream of device to avoid debris getting trapped in the orifices
- Annual inspection of diaphragm integrity is recommended, especially for applications where there is strong or regular pulsing (i.e. reciprocating pump, etc.).
- It is expected that diaphragms will need to be replaced on a regular basis, the timing of which is dependent on the application.
- Repair parts and kits are available for diaphragms and plugs.
- It is recommended to order spare diaphragms prior to performing maintenance. Contact Equilibar to order a “DI Kit” or Diaphragm Kit for this model. Please have the part number available to ensure proper spare parts are ordered.
- Visit our [maintenance website](#) for videos or [contact us](#) for more information at equilbar.com/contact.

PREPARING FOR MAINTENANCE OR TROUBLESHOOTING

- When preparing for maintenance or shutting the system down, turn the process fluid off before removing pilot pressure supply to the pilot port.
- Release the pilot pressure and remove the process piping to clear the BPR for removal and maintenance.
- Loosen the bolts in the cap of the BPR and disassemble wearing proper protective equipment. See exploded view and “Removing PTFE on page 4 for more details.
- Inspect diaphragm and plug for integrity to determine if they need to be replaced or cleaned
- Clean all stainless steel surfaces to remove any residual process fluid and any particles that may have entered
- Reassemble the clean parts with new or cleaned plug and diaphragm following the instructions on page 4.

TROUBLESHOOTING

PROBLEM	POSSIBLE SOLUTIONS
Maximum flow is reduced	Clean out internal orifices
Will not maintain back pressure at low flow rates	1. Inspect the regulator for debris or diaphragm damage which prevents the diaphragm from sealing against the orifice in the regulator body 2. Contact Equilibar Applications Engineer to review low flow specifications
External leak around diaphragm	1. Check for loose screws. If they have loosened, tighten to torque values listed on p.3 2. Check for misaligned flanges, plug or diaphragm 3. Check for scratched sealing surfaces 4. Check plug and diaphragm for damage. Replace as necessary
Chatter on the downstream tubing	1. Increase exhaust piping size 2. Contact factory for additional assistance
Air in process exhaust	Check for ruptured diaphragm
Fluid out of the reference port	Check for ruptured diaphragm

RATED PRESSURE NOTE

Equilibar regulator bodies have a *shell pressure rating* based on the body and bolt strength using principles of the ASME B31.3 and confirmed using hydrostatic testing. These shell pressure ratings are the maximum rating for each design as listed in the technical brochures. For example, FDO6 is listed as having a maximum pressure rating of 150 psig (10bar) standard.

Equilibar configures individual regulators to the specific customer application which may involve fitting the valve with a thinner diaphragm to meet precision or low-flow requirements. The diaphragm selection, operating temperature, chemical composition or other factors may cause pressure derating. Therefore, the MAWP printed on an Equilibar BPR label reflects that of the selected diaphragm and application conditions but will not exceed the shell pressure rating of the body design.

The maximum pressure rating for the shell is always based on the body and bolt strength and is not printed on the product label. Customers may contact Equilibar engineers if they desire to increase unit MAWP by upgrading diaphragm thickness.

Equilibar’s quality system is
ISO 9001:2015 certified.

FDO4 Sanitary Precision Back Pressure Regulator

ASSEMBLY INSTRUCTIONS – FDO4 UNITS WITH PTFE PLUG

If you have the model with upper and lower diaphragms instead, see [FDO4 REV6 I&M](#)

INSTALLING/SEATING NEW PTFE PLUG INTO BODY

NOTE: If PTFE Plug is already installed and **has not shown** signs of damage (typically in the form of leaking), please skip to “Installing a New Diaphragm”

1. Lay Reference (Top) Cap directly on top of Body, aligning holes, without Diaphragm installed.
2. Insert Screws (lock washers shown are not required) through Top Cap and through Body as shown in Figure A.
3. Insert PTFE Plug into the large center cavity in the Body as shown.
4. Position Bottom Cap as shown up against the PTFE plug. Align holes.
5. Tighten all screws finger tight at first. Make sure that the gap is even around the bottom cap.
6. Gradually tighten each of the screws in an opposing pattern as shown in Figure B, keeping an even gap between the Body and the Bottom Cap.
7. Continue tightening in an opposing pattern until there is metal-to-metal contact between the Body and the Bottom Cap. This can take often up to 60 in-lbf (6.8 N-m) torque to properly seat the PTFE plug.
8. Remove Screws and Reference (Top) Cap.

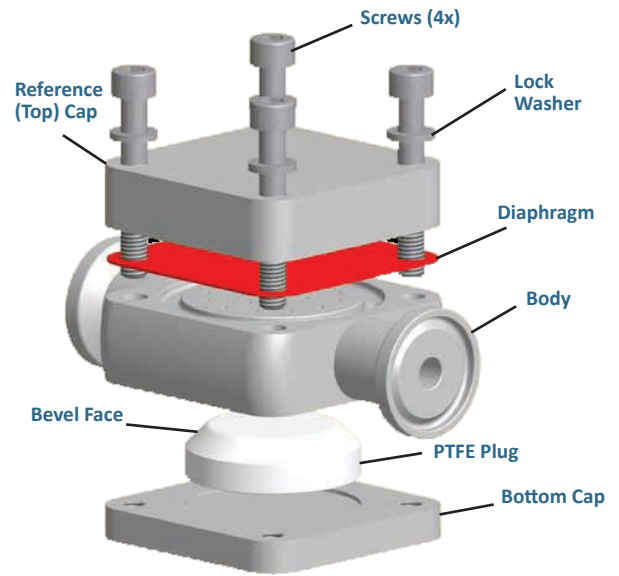

Figure A: Exploded View

INSTALLING A NEW DIAPHRAGM

NOTE: The FDO4 will first be assembled and tightened **WITHOUT** the Diaphragm in order to “seat” the PTFE plug. It will then be reassembled and tightened with the diaphragm. If the PTFE plug **has not been installed** refer to section “Installing/ Seating New PTFE Plug Into Body”

1. Install new Diaphragm on top of Body as shown in Figure A.
2. Install Screws (lock washers shown are not required) through Top Cap and through Diaphragm, then through Body as shown.
3. Tighten all screws finger-tight into Bottom Cap using pattern as shown in Figure B to secure components and prevent uneven torque application.
4. Tighten Screws using the following recommended torque procedure:

Note: *Torque screws slowly with hand tools using the pattern in Figure B to ensure uniform tightening. Motorized or pneumatic torque wrenches are not advised.*

Match the regulator’s diaphragm material to the material in the instructions below for next step:

- For PTFE (Virgin) or PTFE/Glass (PGL) diaphragms, tighten screws to 40 ± 5 in-lbf (4.5 ± 0.5 N-m). Repeat torque pattern at 40 ± 5 in-lbf (4.5 ± 0.5 N-m) until little to no movement of the screw is required to reach final torque. Note: Typical units take 2 to 3 torque repetitions before final torque is maintained.
- For Enhanced PTFE diaphragms, tighten screws to 57 ± 7 in-lbf (6.4 ± 0.8 N-m) using torque pattern. Repeat torque pattern as necessary to reach final torque.
- For FKM or rubber diaphragms, tighten bolts with 25 ± 3 in-lbf (2.8 ± 0.3 N-m) using torque pattern once. Do **not** repeat torque pattern.
- For EPDM diaphragms, tighten bolts to 30 ± 5 in-lbf (3.4 ± 0.6 N-m) using torque pattern.

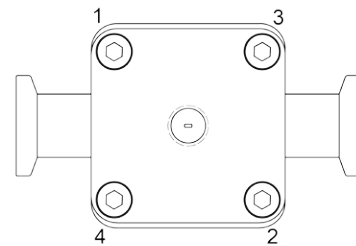

Figure B: Sample Torque Pattern

Apply torque to screw #1 at one corner and then apply torque to the opposite screw (#2). Torque screw #3 and then the final screw, #4.

REMOVING PTFE PLUG

NOTE: PTFE Plug may not require replacement as frequently as diaphragms and it is **not required** to remove plug prior to the installation of a new diaphragm.

1. Insert a small rod into the OD port of the unit.
2. Lightly press on the rod until the PTFE plug is removed. Take care not to scratch unit surfaces.
3. Inspect and replace plug if unusual wear is noticed. Deformation at contact surface is standard.



FDO4 Sanitary Precision Back Pressure Regulator

SYSTEM HAZARD ANALYSIS

Both normal operation as well as possible failure modes and foreseeable misuse must be accounted for in the design of the system which interacts with and connects to the Equilibar back pressure regulator (BPR). It is the responsibility of the end user to account for these hazards. **Please read all of the following safety and hazard precautions before installing or operating any equipment.**

- a. The BPR is not certified as or marketed as a pressure vessel safety relief valve. The BPR is a precision control valve. Guarding against overpressure must be achieved with devices designed and marketed as such.
- b. Sensitive diaphragms and external seals can leak. It is the responsibility of the end user to use this product in a way that prevents injury to personnel should leakage occur. See Standard Terms and Conditions for important Limitation of Liability notes.
- c. If the internal diaphragm ruptures or leaks, the gas or fluid on the pilot port can be introduced into the process fluid. Make sure that the fluids are compatible and not hazardous when mixed.
- d. If the internal diaphragm ruptures or leaks, process fluid can enter the pilot port plumbing.
 - i. Make sure that the process fluids and the pilot are compatible and not hazardous when mixed. Most auxiliary pressure regulators used to provide pilot pressure to the BPR are of the self-relieving design. Guard against the process fluid relieving out the pilot regulator if the BPR diaphragm fails. One method to accomplish this is to set the pilot pressure into a static volume chamber that is sealed with an ON/OFF valve after the pressure is set to the desired value. Another method is to feed the pilot pressure from the pilot regulator through a check valve to the BPR. In order to reduce the pilot pressure a bleed from the pilot port to a safe location must be employed. In many cases this bleed can be made to the output of the BPR.
 - ii. If an electronic pressure regulator is used then special consideration must be made. In addition to reviewing the prospect of having the process media coming in contact with and venting out of the electronic pressure regulator, the possibility of ignition of the media by the electronic pressure regulator must be examined. It is the user's responsibility to determine if a hazardous area classification exists and to make sure that the electronic pressure regulator employed meets or exceeds the requirements of intrinsic safety for that area.
- e. If the internal diaphragm ruptures or leaks the result is often that the BPR will fail into a closed position. This results in a blocked pipe with no path for the fluid to escape through the BPR. Over pressurization of the upstream can occur. Steps must be taken to ensure that the upstream piping is made sufficiently strong to withstand this or is guarded by an overpressure relief device.
- f. Make sure the process pressure to be controlled is connected to the BPR "I" Inlet port. Process fluid flow is from "I" Inlet to the "O" Outlet. If the BPR is connected in reverse, it will still operate but it will give poor control and can result in excess pressures.
- g. Observe the maximum temperature and pressure ratings on the BPR label. Take steps to ensure these values cannot be exceeded. Where necessary to protect equipment, a suitable type of safety overpressure relief valve must be connected in parallel to the BPR. The overpressure relief valve must be rated to prevent the pressure or temperature from exceeding the BPR maximums as listed on the BPR label. In some installations a rupture disc may be substituted for the safety relief valve.
- h. If the discharge piping on the BPR "O" Outlet port becomes blocked, the BPR will open and fill the discharge piping to the same pressure as the maximum pressure in the system. The discharge piping must be rated to contain this pressure or have a safety relief valve to limit this pressure at or below the safe pressure of the discharge piping.
- i. Do not use the BPR as a structural member. All piping and plumbing connections to the BPR should be adequately supported. The BPR series is available with a mounting bracket to facilitate the installation.
- j. Enriched oxygen media (>21%) should not be used in the BPR unless Equilibar has specifically worked with you to provide a product rated and labeled for enriched oxygen. Standard products are not oxygen cleaned. Particle impact, adiabatic compression, and diaphragm motion can all cause ignition in an enriched oxygen media. This kindling chain can cause the entire BPR to oxidize extremely rapidly resulting in high temperatures, discharge of flames and molten metal, and unrestrained escape of process fluid.
- k. The metal cap and body of the BPR are excellent conductors of heat.
 - i. Assume the external temperature of the BPR will rise or fall to match the temperature of the process media flowing through it. In addition to thermal hazards posed to humans by directly touching the BPR exterior, it is the duty of the end user to verify that the temperatures of the process media do not exceed the ignition temperatures of any combustible gases or dust (or mixture) that may be present local to the BPR.
 - ii. Assume the internal temperature of the BPR will rise or fall to match the temperature of the ambient environment. Ensure that the process media flowing through the BPR cannot be damaged or ignited by the maximum and minimum ambient environment temperatures. Low ambient temperatures can cause the media within the regulator to freeze. Expansion cooling in certain gasses can also cause freezing. Freezing can block the BPR and cause excess pressures to build on the "I", Inlet, port. Expansion of water due to freezing can damage the regulator. Ice formation from freezing can perforate metallic foil diaphragms.
- m. The BPR has been carefully designed by skilled engineers to provide proper safety ratios and adequate pressure regulation. Do not attempt to modify the BPR in any way, including adding or enlarging orifices or ports or replacing machine screws (bolts). Only replace the internal O-rings or diaphragms with Equilibar factory provided repair parts.
- n. Never perform maintenance or inspections on a system when pressurized fluids are present. De-pressurize the system before performing this work. De-pressurize inlet pressure before reference otherwise a quick drop in reference pressure can lead to a violent exhaust of the upstream pressure through the regulator.

PATENT INFORMATION

This regulator is subject to one or more of these patents: US6,886,591, US7,080,660, US7,673,650, US8,215,336, DE60322443D1, GB1639282, FR1639282 www.equiblar.com/support/patents/