

# Type 3000 I/P's & E/P's



Type 3110

Type 3111

Type 3120

Type 3210

Type 3220

Type 3211

Type 3221

Type 3212

Type 3222

Type 3215

Type 3410

Type 3411

Type 3420

Type 3510

Type 3520

Type 3511

Type 3521

Type 3512

Type 3522



# Type 3000

## Comparison of I/P's

**Type 3000 Series Comparison Chart**

T1000, T1500, T1001 and T2000	T3000 Series
Steady Air Consumption	Minimal Air Consumption at Steady State
Many are Loop Powered	All Require Supply Voltage
Most Available in Intrinsically Safe or Explosion Proof Versions	No Hazardous Area Approvals
"Standard" Pressure Range to 120 PSI, No Vacuum Models, Limited Low Pressure Control Capability	Wide variety to 600 psi or vacuum, even possible in 0 to 0.2 psi range
Downstream Sensor Feedback Not Available	Second Loop Feedback Available
	Analog and Logic Output Signal Monitoring
	Digital Versions have Keypad or Serial User Interface
	Wide Range of Input Signal/Output Pressure Endpoint, Available in Digital

### Air Quality

Bellofram specifies the use of instrument quality air (clean, dry, oil free) for all transducers. Transducers should be used within the following conditions:

- Dew Point < 35°F (2°C) (indoor)
- Oil Content < 1ppm
- Particles < 3µm.

The use of filters in the supply air system is highly recommended. Contact us for information on our filters and filter regulators.

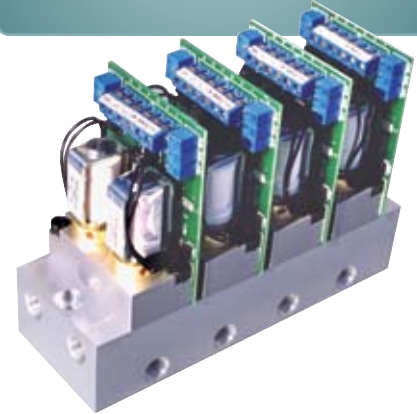

### Type 3000 Series Electro-Pneumatic Transducers

		Packaging				
		DIN-mount Circuit Card	Weatherproof Enclosure			
		Low Flow (1.2 SCFM) (34 LPM)	Low Flow (1.2 SCFM) (34 LPM)	Medium Flow (15 SCFM) (425 LPM)	High Flow (60 SCFM) (1700 LPM)	Very High Flow (175 SCFM) (5000 LPM)
User Interface	Analog 0-10V 4-20mA	T3110, T3120 or T3111	T3210 or T3220	T3211, T3221 or T3311	T3212 or T3222	T3215
	Serial RS-485, RS-232, USB	T3410S or T3420S	T3510S or T3520S	T3511S or T3521S	T3512S or T3522S	
	Keypad/Display Programmer	N/A	T3510P or T3520P	T3511P or T3521P	T3512P or T3522P	
	DeviceNet	T3410D or T3420D	T3510D or T3520D	T3511D or T3521D	T3512P or T3522P	
Mounting	DIN tray, manifold, panel	In-line, DIN-rail, panel bracket, or manifold	In-line, DIN-rail, panel bracket, or manifold	In-line, DIN-rail, panel bracket, or manifold	In-line or panel bracket	

# Type 3000 Series

## Overview

### Features and Capabilities

The Type 3000 series of electro-pneumatic transducers offers an innovative set of features and capabilities. Each electronic pressure regulator utilizes a pair of reliable quick-firing solenoid valves and an onboard pressure sensor to precisely control downstream pressure and at the same time achieve excellent accuracy and stability.

Feed-and-bleed transducers are inherently resistant to shock, vibration, and orientation. To size the regulator for the application, a selection of external volume boosters up to 2000 SCFM (56,000 lpm) are available.

- Analog Control Signals: 0-10v, 4-20 mA, etc.
- Remote Sensor Feedback
- Monitor Output
- High/Low Logic Output
- Digital Signal Processing
- PID Tuning
- Deadband Adjustment
- Serial, Keypad/Display, DeviceNet Interfaces

### Theory of Operation

T3000 transducers utilize proven feed-and-bleed technology. The Supply Solenoid Valve feeds supply pressure to the downstream application. The Exhaust Solenoid Valve bleeds off overpressure. By monitoring the onboard pressure sensor (or the user-supplied remote sensor on two-loop units), the electronics rapidly fire one solenoid or the other to maintain the desired setpoint.

Standard Type 3000s hold output pressure upon loss of electrical power, as long as there are no downstream flow demands. Special versions are available for Fail High or Low Operation.



Type 3110



Type 3210



Type 3211

2nd Loop Adjustments  
(3120 Only)

Control Signal  
Jumpers (V or mA)

Supply Valve

Onboard  
Pressure Sensor

Supply Port

Output Port

Exhaust Port

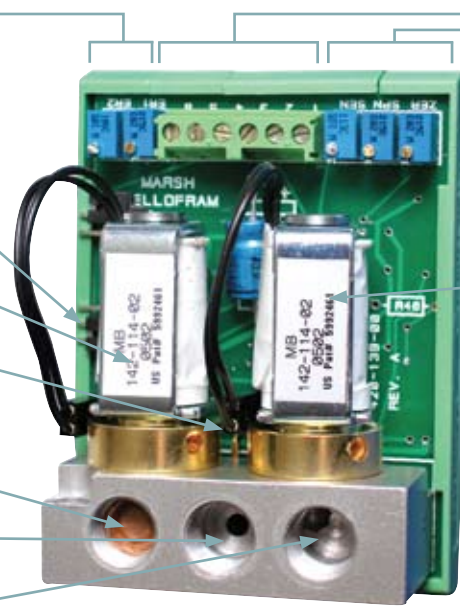

Electrical Connections:  
Control Signal, DC Power, Analog Monitor  
Output, Logic Output, Remote Sensor Feed  
Back, Ground

Zero, Span and Gain Adjustment

Exhaust Valve



# Type 3111

## Analog Circuit-Card Regulators

### Description

The T3111 Compact Analog Pressure Controller is an economical version of the T3100 with no remote feedback or logic output capabilities. Output pressure is limited to 150 PSIG maximum. Jumper selections include AC/DC power and several control signal ranges. Manual output pressure adjustment and differential control signals are available. Overall product dimensions are identical to Type 3110.

### Features

- HVAC application
- Mounts on panel, DIN rail, or directly to multi-station manifold
- Small Footprint
- No Analog Monitor Output
- Economical
- Manual override for output span adjustments



### Type 3111/Ordering Information

111Z	0	150	0	
↑	↑	↑	↑	↑
<b>E</b>				Analog Control Signal
				0-10V
<b>I</b>				0-20 mA
<b>0</b>				0-5V
<b>1</b>				0-15V
	<b>0</b>			Lower Output Pressure
				Lower Limit of Output Pressure
				Pressure Units
		<b>G</b>		PSIG
		<b>A</b>		PSIA absolute
		<b>V</b>		Vacuum
		<b>W</b>		Inches of water column
				Upper Output Pressure
		<b>150</b>		Upper Limit of Output Pressure (PSIG)
				Mounting
			<b>D</b>	DIN Tray
			<b>P</b>	Panel-Mount *
			<b>M</b>	Manifold-Mount
				Supply and Output Ports
			<b>0</b>	1/8 NPT
			<b>1</b>	1/8 BSPT
			<b>2</b>	1/8 BSPP
				Connector
			<b>0</b>	
				Options
			<b>00</b>	None
			<b>14</b>	12 VDC supply

\*For flush panel mounting specify 'P' option and order 161-520-000 bracket.

### Type 3111

Performance	Full-Scale Accuracy 0.5%	
<b>Electrical Inputs</b>		
Supply Voltage	24VDC (12VDC option) 24VAC	
Stand by Supply Current	80 mA	
Maximum Supply Current	250 mA	
E/P Control	0-5V, 0-10V, 0-15V 2K-100K ohms	
I/P Control	0-20 mA , 250 ohms	
<b>Pneumatic Inputs</b>		
	Max. Output PSIG (BAR)	Max. Supply PSIG (BAR)
Supply Pressure	Up to 5 (.35)	20 (1.4)
	>5 to 15 (.35-1.03)	30 (2.1)
	>15 to 30 (1.03-2.1)	60 (4.1)
	>30 to 100 (2.1-6.9)	165 (11.4)
	>100 to 150 (6.9-10.3)	200 (13.8)
<b>Pneumatic Outputs</b>		
Full-scale Atmospheric Pressure Ranges	1, 5, 15, 30, 100, 150 PSIG 0.07, 0.35, 1.03, 2.07, 6.9, 10.34 BAR	
Vacuum Pressure Ranges	30" Hg, 30, 150 PSIA (2.1 BAR, 10.3 BAR)	
Forward Flow Capacity	1.25 SCFM (35.4 LPM)	
Exhaust Flow Capacity	1.25 SCFM (35.4 LPM)	
<b>Environmental</b>		
Operating Temperature	32-141 °F (0-60 °C)	
Media-Wetted Materials	Aluminum, copper alloys, nickel, buna-n, silicon, 316SS	
Recommended Accessories	Manifold, Power Supply, Control Knob, Remote Pressure Sensor, External Volume Booster	

# Type 3210 & 3220

## Analog Weatherproof Regulators

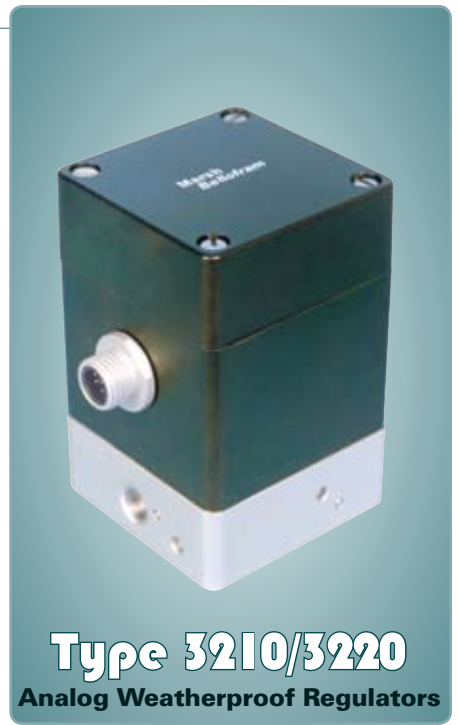

**Type 3210/3220**  
Analog Weatherproof Regulators

### Description

The Type 3210 single loop and 3220 double loop electro-pneumatic servo pressure controllers incorporate two solenoid valves and an internal pressure sensor for increased sensitivity and accuracy. With current or voltage signal inputs, the Type 3210/3220 controls an output pressure with an accuracy of  $\pm .5\%$  or better full scale. A wide range of output pressures available, from 29" Hg vacuum to 600 psig. With a flow of 1.25 SCFM at 100 PSI, the 3210/3220 can be used alone or in conjunction with a volume booster to achieve flow rates in excess of 2,000 SCFM. The double loop (3220) option permits 0-10 VDC feedback from a remote sensor.

Applications include: Semiconductor, Robotics Controller, Machine Automation, Tire Manufacturing and Testing, Molding and Forming Operations and a wide variety of industrial applications.

### Features

- Weatherproof Enclosure
- User Selectable Input Signal
- Analog Monitor Output
- Single Loop and Dual Loop Control
- 1.25 SCFM Flow Rate

### Type 3210/3220 Ordering Information

<b>2</b>	<b>0</b>	<b>0</b>	<b>600</b>	<b>P</b>	<b>1</b>	
▲	▲	▲	▲	▲	▲	Number of Loops
<b>1</b>						1 Loop
<b>2</b>						2 Loop
	<b>0</b>					Logic Output
		<b>M</b>				CMOS
		<b>T</b>				TTL
		<b>O</b>				Open-Collector
						Analog Control Signal
		<b>E</b>				0-10V
		<b>I</b>				4-20mA
			<b>0</b>			Lower Output Pressure Lower Limit of Output Pressure
						Pressure Units
		<b>G</b>				PSIG
		<b>A</b>				PSIA absolute
		<b>V</b>				Vacuum
		<b>W</b>				Inches of water column
			<b>600</b>			Upper Output Pressure Upper Limit of Output Pressure (PSIG)
						Mounting
				<b>P</b>		Pipe (in-line)
						Supply and Output Ports
					<b>0</b>	1/4 NPT
					<b>1</b>	1/4 BSPT
					<b>2</b>	1/4 BSPP
						Connector
					<b>1</b>	Options
					<b>00</b>	None
					<b>14</b>	12 VDC supply
					<b>--</b>	External Volume Booster: X2, X3, Z2, Z3, Z4, N3, N4, N6, N8, Q6, Q8, QA, QB, QC, V2, V3: see chart on page 88

### Type 3210 and 3220

Performance	Full-Scale Accuracy 0.5%	
<b>Electrical Inputs</b>		
Supply Voltage	15-24VDC (12VDC option)	
Stand by Supply Current	80 mA	
Maximum Supply Current	325 mA	
E/P Control	0-10V, 10K OHMS	
I/P Control	4-20 mA, 250 OHMS	
2nd-loop Remote Sensor Feedback	T3220: 0-10V	
<b>Electrical Outputs</b>		
Monitor Output	0-10V	
Logic Output	CMOS, TTL, Open-Collector	
<b>Pneumatic Inputs</b>		
	Max. Output PSIG (BAR)	Max. Supply PSIG (BAR)
Supply Pressure	Up to 5 (.35)	20 (1.4)
	>5 to 15 (.35-1.03)	30 (2.1)
	>15 to 30 (1.03-2.1)	60 (4.1)
	>30 to 100 (2.1-6.9)	165 (11.4)
	>100 to 150 (6.9-10.3)	200 (13.8)
	>150 to 300 (10.3-20.7)	350 (24.1)
	>300 to 600 (20.7-41.4)	650 (44.8)
<b>Pneumatic Outputs</b>		
Full-scale Atmospheric Pressure Ranges	1, 5, 15, 30, 100, 150, 300, 500, 600 PSIG	
	0.07, 0.35, 1.03, 2.07, 6.9, 10.34, 20.68, 34.47, 68.95 BAR	
Vacuum Pressure Ranges	30" Hg, 150 PSIA (2.1 BAR, 10.3 BAR)	
Forward Flow Capacity	1.25 SCFM (35.4 LPM)	
Exhaust Flow Capacity	1.25 SCFM (35.4 LPM)	
<b>Environmental</b>		
Operating Temperature	32-141 ° F (0-60 ° C)	
Media-Wetted Materials	Aluminum, copper alloys, nickel, buna-n, silicon, 316SS	
Required Accessories	6-pin micro cordset	
Recommended Accessories	DIN-rail Bracket, Panel Bracket, Power Supply, Control Knob, Remote Pressure Sensor, External Volume Booster	

# Type 3211 & 3221

## Analog Weatherproof Regulators

### Description

The Type 3211 single loop and 3221 double loop controllers offer non-bleeding solenoid valve technology with an integral flow booster that produces forward flows equivalent to standard industrial electronic regulators or I/P converters. The 3211/3221 offers analog monitoring of the output pressure by a 0-10 VDC signal, plus logic monitor output of the solenoid valves. Many output pressures are available up to 150 psi. A built in air volume booster provides for a forward flow of up to 15 SCFM and a reverse flow (exhaust) of up to 7 SCFM. The double loop (3221) option permits 0-10 VDC feedback from a remote sensor.

Applications include; Machine Automotive, Robotics Control, Web Tension Control, Tire Manufacturing and Testing, Torque Control, Molding and Forming Operations, and Paint Spray.

### Features

- Weatherproof Enclosure
- User Selectable Input Signal
- Analog Monitor Output
- Single Loop and Dual Loop Control



### Type 3211/3221 Ordering Information

2	1	0	150	1	
↑	↑	↑	↑	↑	Number of Loops
1					1 Loop
2					2 Loop
	1				Logic Output
		M			CMOS
		T			TTL
		O			Open-Collector
					Analog Control Signal
		E			0-10V
		I			4-20mA
					Lower Output Pressure
			0		Lower Limit of Output Pressure
					Pressure Units
		G			PSIG
		W			Inches of water column
					Upper Output Pressure
			150		Upper Limit of Output Pressure (PSIG)
					Mounting*
				P	Pipe (in-line)
				M	Manifold-Mount
					Supply and Output Ports
				0	1/4 NPT
				1	1/4 BSPT
				2	1/4 BSPP
					Connector
				1	
					Options
				00	None
				14	12 VDC supply

\*Order panel bracket and DIN rail clip separately.  
For Manifold-Mount (no threads), specify 0 for Supply and Output Ports.

### Type 3211 and 3221

Performance	Full-Scale Accuracy 0.5%	
<b>Electrical Inputs</b>		
Supply Voltage	15-24VDC (12VDC option)	
Stand by Supply Current	80 mA	
Maximum Supply Current	325 mA	
E/P Control	0-10V, 10K OHMS	
I/P Control	4-20 mA , 250 OHMS	
2nd-loop Remote Sensor Feedback	T3221: 0-10V (4-20mA option)	
<b>Electrical Outputs</b>		
Monitor Output	0-10V (4-20 mA option)	
Logic Output	CMOS, TTL, Open-Collector	
<b>Pneumatic Inputs</b>		
	Max. Output PSIG (BAR)	Max. Supply PSIG (BAR)
	Up to 5 (.35)	20 (1.4)
Supply Pressure	>5 to 15 (.35-1.03)	30 (2.1)
	>15 to 30 (1.03-2.1)	60 (4.1)
	>30 to 100 (2.1-6.9)	165 (11.4)
	>100 to 150 (6.9-10.3)	200 (13.8)
<b>Pneumatic Outputs</b>		
Full-scale Atmospheric Pressure Ranges	1, 5, 15, 30, 100, 150 psig	
	0.07, 0.35, 1.03, 2.07, 6.9, 10.34 BAR	
Forward Flow Capacity	15 SCFM 425 LPM	
Exhaust Flow Capacity	7 SCFM 198 LPM	
<b>Environmental</b>		
Operating Temperature	32-141 °F (0-60 °C)	
Media-Wetted Materials	Aluminum, copper alloys, nickel, buna-n, silicon, 316SS	
Required Accessories	6-pin micro cordset	
Recommended Accessories	DIN-rail Bracket, Panel Bracket, Power Supply, Control Knob, Remote Pressure Sensor, External Volume Booster	

# Type 3212 & 3222

## Analog Weatherproof Regulators

### Description

The Type 3212 single loop and 3222 double loop are non-bleeding electro-pneumatic controller with flows exceeding those of most compact standard industrial electronic regulators or I/P transducers. The 3212/3222 offers analog monitoring of the output pressure by a 0-10 VDC signal. Many output pressures are available up to 150 PSI. Flows to 60 SCFM are possible from the compact Type 3212/3222 electronic controller with integrated booster relay. A reliable twin solenoid valve system, with an integral pressure sensor, controls pressures to an accuracy of  $\pm .5\%$ . Custom output ranges are available.

Applications include: Automotive, Industrial Machinery, Web Tension Control, and Tire Manufacturing and Testing.

### Features

- Closed Loop Technology
- Integrated Air Volume Booster
- Current/Voltage Command and Monitor Signals
- Compact Unit with Flows up to 50 SCFM



**Type 3212/3222**  
Analog Weatherproof Regulators

### Type 3212/3222 Ordering Information

2	2	0	G	150	P	1	
↑	↑	↑	↑	↑	↑	↑	Number of Loops
1							1 Loop
2							2 Loop
	2						
		M					Logic Output CMOS
		T					TTL
		O					Open-Collector
			E				Analog Control Signal 0-10V
			I				4-20mA
				O			Lower Output Pressure Lower Limit of Output Pressure
					G		Pressure Units PSIG
						150	Upper Output Pressure Upper Limit of Output Pressure (PSIG)
						P	Mounting Pipe (in-line)
							Supply and Output Ports
						0	1/4 NPT
						1	1/4 BSPT
						2	1/4 BSPP
						3	3/8 NPT
						4	3/8 BSPT
						5	3/8 BSPP
							Connector
						1	
							Options
						00	None
						14	12 VDC supply

### Type 3212 and 3222

Performance	Full-Scale Accuracy 0.5%	
<b>Electrical Inputs</b>		
Supply Voltage	15-24VDC (12VDC option)	
Stand by Supply Current	80 mA	
Maximum Supply Current	325 mA	
E/P Control	0-10V, 10K OHMS	
I/P Control	4-20 mA, 250 OHMS	
2nd-loop Remote Sensor Feedback	T3222: 0-10V (4-20mA option)	
<b>Electrical Outputs</b>		
Monitor Output	0-10V	
Logic Output	CMOS, TTL, Open-Collector	
<b>Pneumatic Inputs</b>		
	Max. Output PSIG (BAR)	Max. Supply PSIG (BAR)
	Up to 5 (.35)	20 (1.4)
	>5 to 15 (.35-1.03)	30 (2.1)
	>15 to 30 (1.03-2.1)	60 (4.1)
	>30 to 100 (2.1-6.9)	165 (11.4)
	>100 to 150 (6.9-10.3)	200 (13.8)
Supply Pressure		
<b>Pneumatic Outputs</b>		
Full-scale Atmospheric Pressure Ranges	1, 5, 15, 30, 100, 150, 300 PSIG	
	0.07, 0.35, 1.03, 2.07, 6.9, 10.34, 20.68 BAR	
Forward Flow Capacity	60 SCFM (1700 LPM)	
Exhaust Flow Capacity	15 SCFM (425 LPM)	
<b>Environmental</b>		
Operating Temperature	32-141 °F (0-60 °C)	
Media-Wetted Materials	Aluminum, copper alloys, nickel, buna-n, silicon, 316SS	
Required Accessories	6-pin micro cordset	
Recommended Accessories	DIN-rail Bracket, Panel Bracket, Power Supply, Control Knob, Remote Pressure Sensor, External Volume Booster	

# Type 3215

## Weatherproof Regulator with Super High Flow

### Description

The T3215 High-Flow Pressure Controller utilizes reliable, quick-firing solenoids, an onboard pressure sensor, and a precision 180 scfm booster to achieve excellent accuracy and stability. There are many custom output ranges between 0 and 150 PSIG (1.0 MPa). The T3215 is CE-rated, weatherproof, and vibration-resistant. Analog electrical connections include control and monitor output. Mounting options include in-line and panel.

The T3215 is available with or without pressure monitor and logic outputs (6-pin or 4-pin micro connector, respectively). The T3215 is also available with a 6-pin DIN 43650 connector. Differential inputs mean problem-free integration with PLC grounding systems.

### Features

- Single Unit-Integrated Controller and Booster
- Very High Flow Volume Booster-Greater than 200 SCFM
- High Accuracy Control of Air Pressure
- Low Air Consumption
- Weatherproof Housing
- Shock Resistant, Position Insensitive
- CE Approved

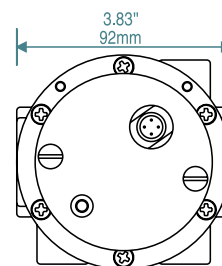
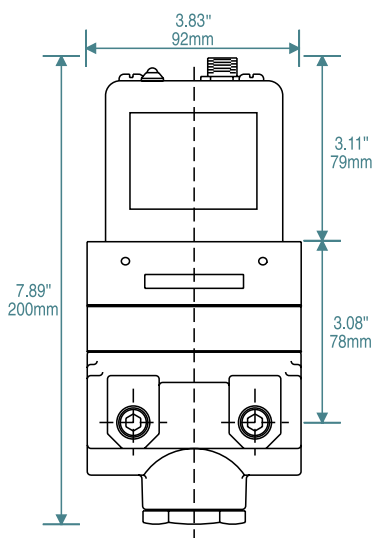

### Type 3215 Ordering Information

215		O	G		P			OO	
	▲								Logic Output
	M								CMOS
	T								TTL
	O								Open-Collector
	Z								No Logic Output
									Analog Control Signal
	E								0-10V
	I								4-20mA
									Lower Output Pressure
		O							Lower Limit of Output Pressure
									Pressure Units
			G						PSIG
									Upper Output Pressure
							030		30 PSIG
							100		100 PSIG
							150		150 PSIG
									Mounting
								P	Pipe (in-line)
									Supply and Output Ports
								3	3/8 NPT
								4	1/2 BSPT
								6	3/4 BSPP
								8	1 NPT
									Connector
								1	Micro Connector
								D	DIN 43650 Connector
									Options
								OO	None

### Type 3215

Performance	Full-Scale Accuracy 1.0%	
<b>Electrical Inputs</b>		
Supply Voltage	15-24VDC (12VDC option)	
Stand by Supply Current	80 mA	
Maximum Supply Current	325 mA	
E/P Control	0-10V, 10K OHMS	
I/P Control	4-20 mA , 250 OHMS	
<b>Electrical Outputs</b>		
Monitor Output	0-10V	
Logic Output	CMOS, TTL, Open-Collector	
<b>Pneumatic Inputs</b>	Max. Output PSIG (BAR)	Max. Supply PSIG (BAR)
Supply Pressure	Up to 5 (.35)	20 (1.4)
	>5 to 15 (.35-1.03)	30 (2.1)
	>15 to 30 (1.03-2.1)	60 (4.1)
	>30 to 100 (2.1-6.9)	165 (11.4)
	>100 to 150 (6.9-10.3)	200 (13.8)
<b>Pneumatic Outputs</b>		
Full-scale Atmospheric Pressure Ranges	30, 100, 150, PSIG	
Forward Flow Capacity	180 SCFM (5100 LPM)	
Exhaust Flow Capacity	30 SCFM (850 LPM)	
<b>Environmental</b>		
Operating Temperature	32-141 °F (0-60 °C)	
Media-Wetted Materials	Aluminum, copper alloys, nickel, buna-n, silicon, 316SS	
Required Accessories	4 or 6-pin micro cordset	
Recommended Accessories	Panel Bracket, Power Supply, Control Knob, External Volume Booster	

# External Volume Boosters

## Description

Volume Boosters increase the flow capacity of electro-pneumatic transducers, leading to faster response time and increased ability to remain at setpoint.

Low-flow transducers (T3210, T3220, T3510, and T3520) can be mounted on the volume booster of your choice. Simply add the booster's 2-letter code (from below) to the Options field of the T3000 part number.

The RPS sensor can be used with two-loop transducers (T3120, T322X, T3420, and T352X), closing the loop to the booster's output and increasing overall accuracy.

When the distance between transducer and volume booster is large (e.g., when the transducer is mounted in a cabinet and the booster is installed directly at the application), one of the high-flow transducers (e.g., T3211 or T3512) can drive the booster over distance.

The X booster is the Marsh Bellofram Type 20EXHR. It utilizes two-stage technology to maintain setpoint over a wide range of flows

(Note: minimum output is 2 PSIG). The Z booster is the Marsh Bellofram Type 75HR. The N booster is the Marsh Bellofram Type 79. Consult the documentation for these products for more information.



The Q boosters are ultra-high flow boosters. The V booster can be used with vacuum versions of the T3210, T3220, T3510, and T3520.

Flow capacities are for comparison purposes only. Forward flow is typically measured at 100 PSIG / 6.9 BAR supply and 80 PSIG / 5.5 BAR output. Exhaust flow is typically measured at 5-10 psig / 8.3-6.7 BAR above 20 PSIG setpoint.



External Volume Boosters

## External Volume Boosters

Part Number	Marsh Bellofram Booster	Supply and Output Port Size (NPT)	Maximum Supply (PSIG / BAR)	Maximum Signal and Output (PSIG / BAR)	Typical Forward Flow (SCFM / SLPM)	Typical Exhaust Flow (SCFM / SLPM)	
X2	T20 EX HR Pg. 40		1/4	150 / 10.3	120 / 8.3	14 / 396	10 / 283
X3			3/8	150 / 10.3	120 / 8.3	14 / 396	10 / 283
Z2	T75 HR Pg. 42		1/4	250 / 17.2	150 / 10.3	40 / 1133	15 / 425
Z3			3/8	250 / 17.2	150 / 10.3	50 / 1416	15 / 425
Z4			1/2	250 / 17.2	150 / 10.3	50 / 1416	15 / 425
N3	T79 Pg. 43		3/8	400 / 27.6	200 / 13.8	170 / 4814	31 / 878
N4			1/2	400 / 27.6	200 / 13.8	200 / 5664	31 / 878
N6			3/4	400 / 27.6	200 / 13.8	220 / 6230	31 / 878
N8			1	400 / 27.6	200 / 13.8	220 / 6230	31 / 878
Q6			3/4	300 / 20.7	160 / 11	550 / 15576	220 / 6230
Q8			1	300 / 20.7	160 / 11	550 / 15576	220 / 6230
QA			1-1/4	300 / 20.7	160 / 11	2200 / 62304	200 / 5664
QB			1-1/2	300 / 20.7	160 / 11	2200 / 62304	200 / 5664
QC			2	300 / 20.7	160 / 11	2200 / 62304	200 / 5664
V2			1/4	140 / 9.7	100 / 6.9	50 / 1416	6 / 170
V3			3/8	140 / 9.7	100 / 6.9	50 / 1416	6 / 170

# Digital Electro-Pneumatic Transducers

## Features

### Multiple User Interfaces

(See examples on these pages)

- Analog interface (mA or voltage signal)
- Serial RS-485 (RS-232 and USB via converters) – use our program or write your own, as several high tech customers have done! Control up to 24 addressable units on an RS485 link. The serial link permits customizing the factory settings to your needs.
- Keypad /display: easily configure the transducer to your needs
- DeviceNet through serial communications link

### Input and Output Settings

With keypad or serial communications, you can set almost any low and high end points (input/output points) within the range of the selected sensor. You are not limited to points on a linear zero to maximum span I/O plot as on other I/Ps and E/Ps. *(For example, if your primary process settings require an output of 25 PSI at 2 volts signal and 50 PSI at 8.5 volts, you can choose those as your "Cal-L" and "Cal-H" points and the unit will be linear between those two settings. If you would like the reverse, then select 50 PSI at 2 volts, and so forth.)*

- Capability to change PID settings to match your system requirements
- Second loop feedback (from a remote sensor) available. Digital units permit user to add, delete, or scale the second loop signal.
- Choices of circuit card mounted or weather-proof factory/field units
- Very wide range of output pressures, including vacuum, absolute, and high pressures.
- Monitor output signal options
- Resistant to vibration and changes in orientation
- Multiple mounting options

## Digital Circuit-Card Regulators

The compact Type 3410 (one-loop) and 3420 (two-loop) Circuit-Card Pressure Regulators are perfect for size-conscious OEM's, without sacrificing any of the high-end performance normally associated with full-size I/P's.

The T3400 can be controlled digitally or with industry-standard analog control signals (0-10V or 4-20mA). Industry-standard analog monitor output signals (0-10V or 4-20mA optional) are available for user-monitoring of actual output pressure.

### Electrical Connections

- Serial RS-485 Connections
- DC Power
- Optional Monitor Output, Analog Setpoint and Remote Sensor Feedback

- Analog Interface



### Keypad/Display Interface

Selection include: input signal, minimum and maximum input signal/output values, units in the display, second loop feedback signal settings, deadband, and proportional gain factor.

A CD with the user manual and a program to configure and control the serial units is included with all digital units, including those with keypad. A small adapter cable is included to permit removal of the keypad to connect to a computer PID settings and other functions not available through the keypad. In effect, this permits serial communications with the keypad removed.

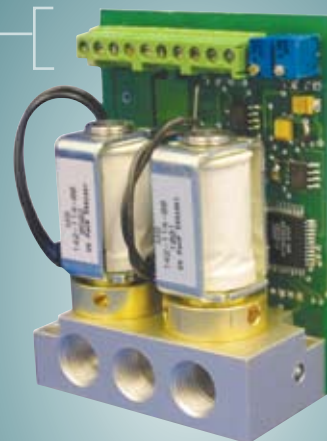

T3410S  
Panel Mount

## Type 3400 Circuit-Card Regulators



## Type 3500 Digital Weatherproof Regulators with Keypad

# Digital User Interfaces

## Type 3000 Serial RS-485 User Interfaces

### Serial RS-485 User Interface

(RS-232 and USB via converters)

User connection to the T3500 serial interface is made via the 4-pin connector near the top of the product. The 4N cordset is a required accessory.

User connection to the T3400 serial interface is made via the product's terminal block.

- Serial Interface
- Analog Interface

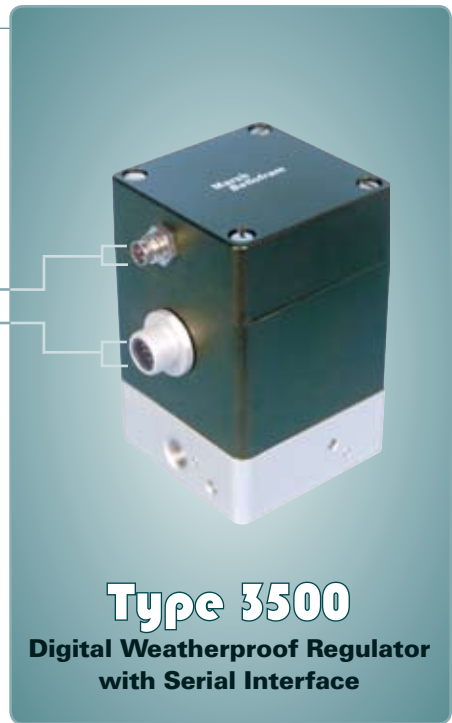

### Type 3500

Digital Weatherproof Regulator with Serial Interface

DeviceNet Connections

Serial to DeviceNet Bridge

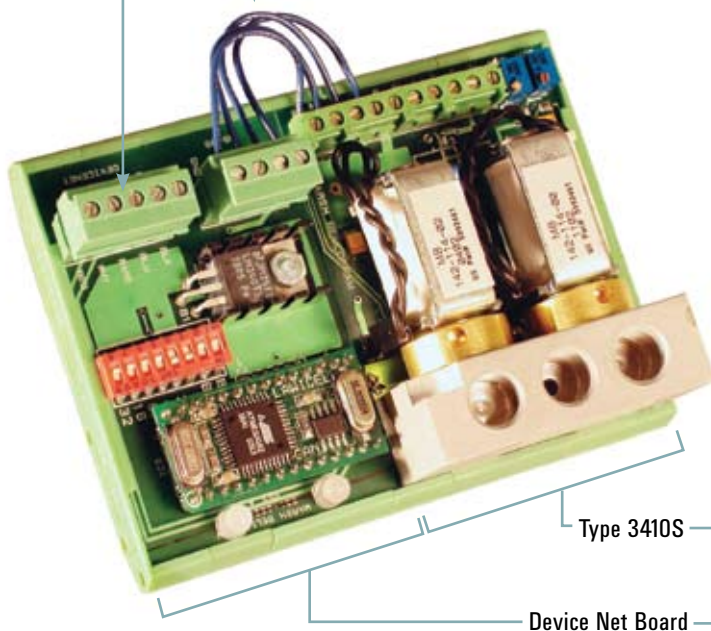

Type 3410S

Type 3410D  
(Din Tray Mount Shown)

Device Net Board

### DeviceNet

The T3500D DeviceNet cap communicates with its Base through a Serial Communications link. The 5P cordset is a required accessory. DeviceNet communication with the T3500D includes Send Setpoint and Get Actual Pressure. The EDS file and Device Profile are available upon request.

#### DeviceNet Connection

(5-pin micro-style connector)

- Power Supplied by DeviceNet bus
- Voltage: 11 to 25 VDC
- Current: 70 mA at 12 VDC (nominal)

#### Base Power

(6-pin micro-style connector)

- Must be supplied by user
- Voltage: 24VDC (+/-1VDC) — (15VDC optional)
- Current: 375 mA maximum

#### Network Specifics

- Compatibility: Group 2 Server Only, not UCMM capable.
- Baud Rates: 125 Kbaud, 250 Kbaud, and 500 Kbaud.
- Bus Interface: Phillips 82C250; mis-wiring protection per DeviceNet Vol. I Sec 10.2.2.

- Node Isolation: Bus powered, optically isolated node.
- Bus Connection: Micro connector per DeviceNet Volume I Appendix C-5.
- Factory Defaults: Baud rate = 125 K baud. MAC ID = 63.
- Device Type: 0 (Generic)
- Device Profile: DeviceNet Specification (Volumes I and II of version 2.0).
- Device Configuration: No DeviceNet configuration is supported.
- Status LED's: Network Status (NS) and Module Status (MS) LED's are provided.

# Type 3410 & 3420

## Digital Circuit-Card Regulators

### Description

The compact Type 3410 (one-loop) and 3420 (two-loop) Circuit-Card Pressure Regulators are perfect for size-conscious OEM's, without sacrificing any of the high-end performance normally associated with full-size I/P's.

The T3400 is available with either of two user interfaces: the T3400S with serial interface or the T3400D with DeviceNet interface. The T3400D consists of the T3400S plus a sister board for DeviceNet functions.

The T3400 can be controlled digitally (via the serial or DeviceNet interfaces) or with industry standard analog control signals (0-10V or 4-20mA). Industry-standard analog monitor output signals (0-10V or 4-20mA optional) are available for user-monitoring of actual output pressure.

### Features

- Small Footprint
- Serial or DeviceNet Interface
- Digital or Analog Inputs
- Analog Monitor Output
- Single Loop and Dual Loop Control



**Type 3410/3420**  
Digital Circuit-Card Regulators

### Type 3410 and 3420 Ordering Information

4	0	0	600	0	
▲	▲	▲	▲	▲	▲▲ Loops
1					1 loop
2					2 loops
0					
	S				Digital Interface
	D				Serial RS-485 (RS-232 and USB via converters)
					DeviceNet
					Analog Control Signal
	E				0-10V
	I				4-20mA
					Lower Output Pressure
		O			Lower Limit of Output Pressure
					Pressure Units
			G		PSIG
			A		PSIG Absolute
			V		Vacuum
			W		Inches of Water Column
					Upper Output Pressure
			600		Upper Limit of Output Pressure
					Mounting
				D	DIN tray
				P	Panel Mount
				M	Manifold-Mount (150 PSIG/ 16.3 BAR max output)
					Supply and Output Ports
				0	1/4 NPT
				1	1/4 BSPT
				2	1/4 BSPP
					Options
				00	None
				15	15VDC Supply

\* Type 3400 DeviceNet "D" mounting, Type 3400S and DeviceNet board installed in a single extended DIN tray. 'P' or 'M' mounting, DeviceNet board is supplied with 4 screws and stand-offs for panel mounting.

### Type 3410 and 3420

Performance	Full-Scale Accuracy 0.5%
<b>Electrical Inputs</b>	
Supply Voltage	24VDC (optional 15VDC)
Stand by Supply Current	80 mA
Maximum Supply Current	250 mA
<b>Supply Pressure</b>	
Atmospheric Pressure Ranges	1, 5, 15, 30, 100, 150, 300, 500 PSIG
Vacuum Pressure Ranges	0.07, 0.35, 1.03, 2.07, 6.9, 10.34, 20.68, 34.47, 68.95 BAR
Forward Flow Capacity	1.25 SCFM (35.4 LPM)
Exhaust Flow Capacity	1.25 SCFM (35.4 LPM)
<b>Analog Setpoint Control</b>	
Digital Setpoint Control	0-100% full scale (installed sensor=100%)
<b>Digital Communications</b>	
Serial Address	Addresses a-z available (except p and q reserved). 'r' default*
<b>Loop Options</b>	
Remote Sensor Feedback	0-10V, 0-5V, 4-20 mA, (Forward and Reverse Acting)*
Analog Output Source	Follow Setpoint, Output Pressure, or Remote Sensor*
Analog Output Range	0-10V, 0-5V*
<b>Environmental</b>	
Operating Temperature	32-141 °F (0-60 °C)
Media-Wetted Materials	Aluminum, copper alloys, nickel, buna-n, silicon, 316SS

\* Selectable and configurable via Serial or DeviceNet Interface



# Type 3510 & 3520

## Digital Weatherproof Regulators

### Description

The Type 3510 single and 3520 double loop electro-pneumatic servo pressure controllers combine the advantages of reliable solenoid valves and digital control. Available with a local keypad programming option or RS-485 Digital Communications for PLC or PC control. The digital pressure controller is one of the most precise, accurate, and reliable devices available in the industry today, by giving the user the ability to set and extract data directly from the transducer with a PC or automation system. With a forward flow of 1.25 SCFM at 100 PSI, the 3510/3520 can be used alone for many applications or combined with a volume booster for flows in excess of 2,000 SCFM. Many output ranges are available, from 29" Hg vacuum to 600 PSIG. Standard accuracy is  $\pm 0.5\%$  FS or better. A four digit display of the output pressure is available with the keypad model.

Applications include: Gripper Control, Welding Operations, Actuator Control, Machinery Automation, Precision Robotics, Tire Production and Testing, Web Tension, Semiconductor Equipment, and Molding and Forming Operations.

### Features

- Digital Display
- Serial or DeviceNet Interface
- Digital or Analog Inputs
- Analog Monitor Output
- Single Loop and Dual Loop Control
- Forward Flow 1.25 SCFM at 100 PSI
- Weather Proof Housing

### Type 3510 and 3520 Ordering Information

5	4	3	2	1	0	Options
0	0	600	P	1		Loops
1						1 loop
2						2 loops
0						Digital Interface
S						Serial RS-485 (RS-232 and USB via converters)
P						Keypad/display programmer
D						DeviceNet
						Analog Control Signal
E						0-10V
I						4-20mA
						Lower Output Pressure
0						Lower Limit of Output Pressure (PSIG)
						Pressure Units
G						PSIG
A						PSIG Absolute
V						Vacuum
W						Inches of Water Column
						Upper Output Pressure
		600				Upper Limit of Output Pressure
						Mounting
			P			Pipe Mount
						Supply and Output Ports
				0		1/4 NPT
				1		1/4 BSPT
				2		1/4 BSPP
					1	Options
					00	None
					15	15VDC Supply
					--	External Volume Booster: X2, X3, Z2, Z3, Z4, N3, N4, N6, N8, Q6, Q8, QA, QB, QC, V2, V3: see chart on page 88



**Type 3510/3520**  
Digital Weatherproof Regulators

### Type 3510/3520

Performance	Full-Scale Accuracy 0.5%	
<b>Electrical Inputs</b>		
Supply Voltage	24VDC (optional 15VDC)	
Stand by Supply Current	80 mA	
Maximum Supply Current	325 mA	
<b>Supply Pressure</b>	Max. Output PSIG (BAR)	Max. Supply PSIG (BAR)
	Up to 5 (.35)	20 (1.4)
	>5 to 15 (.35-1.0)	30 (2.1)
	>15 to 30 (1.0-2.1)	60 (4.1)
	> 30 to 100 (2.1-6.9)	165 (11.4)
	>100 to 150 (6.9-10.3)	200 (13.8)
	>150 to 300 (10.3-20.7)	350 (24.1)
	>300 to 600 (20.7-41.4)	650 (44.8)
<b>Outputs</b>		
Atmospheric Pressure Ranges	1, 5, 15, 30, 100, 150, 300, 500, 600 PSIG	
Vacuum Pressure Ranges	0.07, 0.35, 1.03, 2.07, 6.9, 10.34, 20.68, 34.47, 68.95 BAR	
Forward Flow Capacity	1.25 SCFM (425 LPM)	
Exhaust Flow Capacity	1.25 SCFM (198 LPM)	
Analog Setpoint Control	0-5V, 0-10V, 4-20mA	
Digital Setpoint Control	0-100% full scale (installed sensor=100%)	
Digital Communications	Serial RS-485 interface	
Serial Address	Addresses a-z available (except p and q reserved). 'r' default selectable and configurable via Serial or Keypad Display Interface	
Loop Options	Regulate first loop (onboard sensor) or 2nd loop (remote sensor)	
Remote Sensor Feedback	0-10V, 0-5V, 4-20 mA, (Forward and Reverse Acting)	
Analog Output Source	Follow Setpoint, Output Pressure, or Remote Sensor	
Analog Output Range	0-10V, 0-5V	
<b>Environmental</b>		
Operating Temperature	32-141 °F (0-60 °C)	
Media-Wetted Materials	Aluminum, copper alloys, nickel, buna-n, silicon, 316SS	

# Type 3511 & 3521

## Digital Weatherproof Regulators

### Description

The 3511 offers solenoid valve technology with forward flow equivalent to standard industrial electronic regulators or I/P transducers. Available with local keypad programming option or RS-485 Digital Communications for PLC or PC control. Dual solenoid valves with internal pressure sensor and advanced microprocessor control. A built-in air volume booster provides the 3511 with forward flow up to 17 SCFM. Proportional - Integral - Derivative (PID) control. Ranges from 0 to 150 PSIG. Reverse flow (exhaust) of up to 7 SCFM. The double loop (3521) option permits 0-10 VDC feedback from a remote sensor. The keypad is available with a four digit display of the output pressure.

Applications include: Gripper Control, Welding Operations, Actuator Control, Machinery Automation, Precision Robotics, Tire Production and Testing, Web Tension Semiconductor Equipment and Molding and Forming Operations.

### Features

- Serial or DeviceNet Interface
- Digital or Analog Inputs
- Analog Monitor Output
- Single Loop and Dual Loop Control
- Forward Flow up to 17 SCFM
- Digital Display
- Weather Proof Housing

### Type 3511 and 3521 Ordering Information

5	1	0	150	P	1		
↑	↑	↑	↑	↑	↑	↑	Loops
1							1 loop
2							2 loops
	1						
							Digital Interface
				S			Serial RS-485 (RS-232 and USB via converters)
				P			Keypad/display programmer
				D			DeviceNet
							Analog Control Signal
				E			0-10V
				I			4-20mA
							Lower Output Pressure
		0					Lower Limit of Output Pressure
							Pressure Units
				G			PSIG
				W			Inches of Water Column
							Upper Output Pressure
			150				Upper Limit of Output Pressure
							Mounting*
				P			Pipe Mount
				M			Manifold-Mount
							Supply and Output Ports
					0		1/4 NPT
					1		1/4 BSPT
					2		1/4 BSPP
						1	
							Options
					00		None
					15		15VDC Supply

\*Order panel bracket and DIN rail clip separately.  
For Manifold-Mount (no threads), specify 0 for Supply and Output Ports.



**Type 3511/3521**  
Digital Weatherproof Regulators

### Type 3511/3521

Performance	Full-Scale Accuracy 0.5%	
<b>Electrical Inputs</b>		
Supply Voltage	24VDC (optional 15VDC)	
Stand by Supply Current	80 mA	
Maximum Supply Current	325 mA	
<b>Supply Pressure</b>	Max. Output PSIG (BAR)	Max. Supply PSIG (BAR)
	Up to 5 (.35)	20 (1.4)
	>5 to 15 (.35-1.0)	30 (2.1)
	>15 to 30 (1.0-2.1)	60 (4.1)
	> 30 to 100 (2.1-6.9)	165 (11.4)
	>100 to 150 (6.9-10.3)	200 (13.8)
<b>Outputs</b>		
Atmospheric Pressure Ranges	5, 15, 30, 100, 150 PSIG 0.35, 1.03, 2.07, 6.9, 10.34 BAR	
Forward Flow Capacity	15 SCFM (425 LPM)	
Exhaust Flow Capacity	7 SCFM (198 LPM)	
Analog Setpoint Control	0-5V, 0-10V, 4-20mA	
Digital Setpoint Control	0-100% full scale (installed sensor=100%)	
Digital Communications	Serial RS-485 interface	
Serial Address	Addresses a-z available (except p and q reserved). 'r' default selectable and configurable via Serial or Keypad Display Interface	
Loop Options	Regulate first loop (onboard sensor) or 2nd loop (remote sensor)	
Remote Sensor Feedback	0-10V, 0-5V, 4-20 mA, (Forward and Reverse Acting)	
Analog Output Source	Follow Setpoint, Output Pressure, or Remote Sensor	
Analog Output Range	0-10V, 0-5V	
<b>Environmental</b>		
Operating Temperature	32-141 °F (0-60 °C)	
Media-Wetted Materials	Aluminum, copper alloys, nickel, buna-n, silicon, 316SS	

# Type 3512 & 3522

## Digital Weatherproof Regulators

### Description

The Type 3512 single loop and 3522 double loop are single units - integrated controller and booster. The 3512/3522 offers solenoid valve technology with forward flow exceeding those of most standard industrial electronic regulators or I/P transducers. Available with a local keypad programming option or RS-485 digital communications for PLC or PC control. Many output pressure ranges are available up to 150 PSI. With a reliable twin solenoid valve system, and an integral pressure sensor, an accuracy of  $\pm 0.5\%$  is obtainable.

Applications include; Gripper Control, Welding Operations, Actuator Control, Machinery Automation, Precision Robotics, Web Tension, Semiconductor Equipment, Molding and Forming Operations and Tire Manufacturing and Testing.

### Features

- Serial or DeviceNet Interface
- Digital or Analog Inputs
- Analog Monitor Output
- Single Loop and Dual Loop Control
- Forward Flow up to 60 SCFM
- Digital Display



### Type 3512 and 3522 Ordering Information

5	2	0	150	P	1	
↑	↑	↑	↑	↑	↑	Loops
1						1 loop
2						2 loops
2						
						Digital Interface
	S					Serial RS-485
	P					(RS-232 and USB via converters)
	D					Keypad/display programmer
						DeviceNet
						Analog Control Signal
	E					0-10V
	I					4-20 mA
						Lower Output Pressure
		O				Lower Limit of Output Pressure
						Pressure Units
				G		PSIG
						Upper Output Pressure
			150			Upper Limit of Output Pressure
						Mounting
				P		Pipe Mount
						Supply and Output Ports
					0	1/4 NPT
					1	1/4 BSPT
					2	1/4 BSPP
					3	3/8 NPT
					4	3/8 BSPT
					5	3/8 BSPP
					1	
						Options
					00	None
					15	15 VDC Supply

### Type 3512/3522

Performance	Full-Scale Accuracy 0.5%	
<b>Electrical Inputs</b>		
Supply Voltage	24VDC (optional 15VDC)	
Stand by Supply Current	80 mA	
Maximum Supply Current	325 mA	
<b>Supply Pressure</b>	Max. Output PSIG (BAR)	Max. Supply PSIG (BAR)
	Up to 5 (.35)	20 (1.4)
	>5 to 15 (.35-1.0)	30 (2.1)
	>15 to 30 (1.0-2.1)	60 (4.1)
	> 30 to 100 (2.1-6.9)	165 (11.4)
	>100 to 150 (6.9-10.3)	200 (13.8)
<b>Outputs</b>		
Atmospheric Pressure Ranges	5, 15, 30, 100, 150 PSIG 0.35, 1.03, 2.07, 6.9, 10.34 BAR	
Forward Flow Capacity	60 SCFM (1700 LPM)	
Exhaust Flow Capacity	15 SCFM (425 LPM)	
Analog Setpoint Control	0-5V, 0-10V, 4-20mA	
Digital Setpoint Control	0-100% full scale (installed sensor=100%)	
Digital Communications	Serial RS-485 interface	
Serial Address	Addresses a-z available (except p and q reserved). 'r' default selectable and configurable via Serial or Keypad Display Interface	
Loop Options	Regulate first loop (onboard sensor) or 2nd loop (remote sensor)	
Remote Sensor Feedback	0-10V, 0-5V, 4-20 mA, (Forward and Reverse Acting)	
Analog Output Source	Follow Setpoint, Output Pressure, or Remote Sensor	
Analog Output Range	0-10V, 0-5V	
<b>Environmental</b>		
Operating Temperature	32-141 °F (0-60 °C)	
Media-Wetted Materials	Aluminum, copper alloys, nickel, buna-n, silicon, 316SS	

# Dimensional Drawings

## DIN Tray Mount

(3100, 3400) Dust Cover = 157-201-01

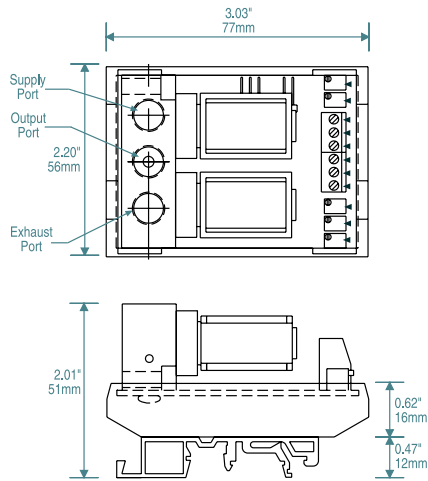

## Panel Mount

(3100, 3400)

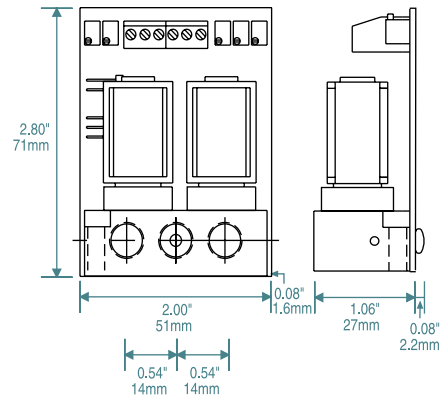

## Manifold Mount

(3100, 3400)

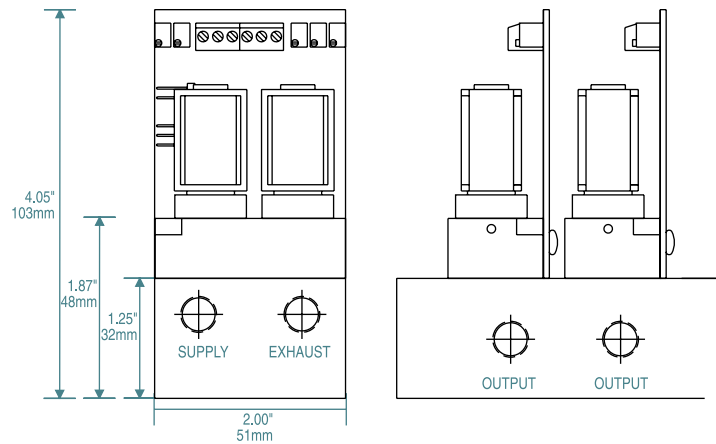

## High-Pressure Units (>300 PSIG) T3111, 3410 and 3420

High Pressure (>300 PSIG / 20.7 BAR) units

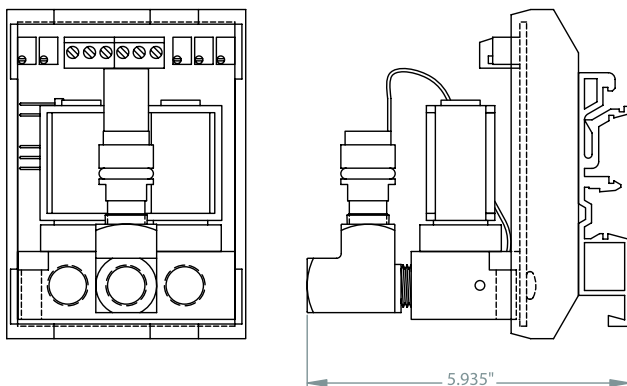

## Flush Panel Mount T3100, T3111

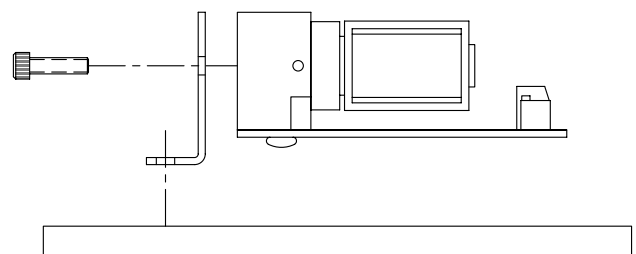

## Type 3100 and 3400 Series Manifold Block ( 7 Station Manifold Shown)

( 7 station manifold shown)

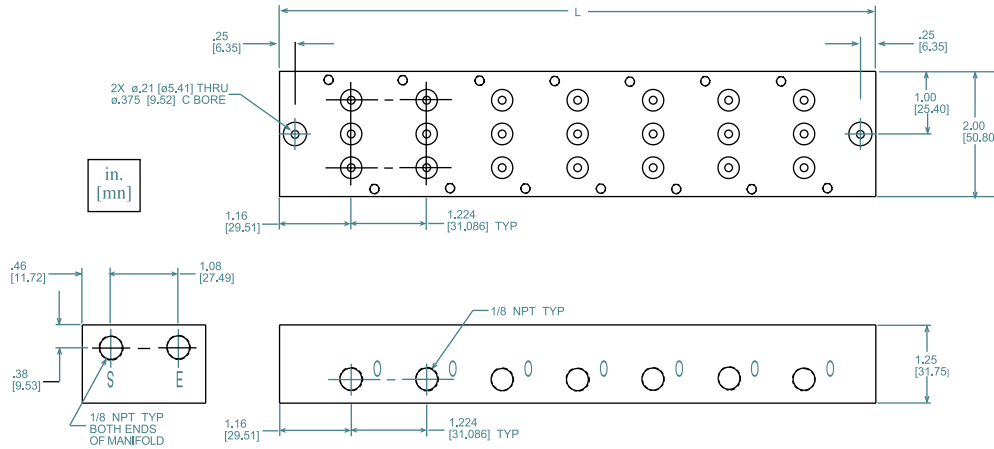

Manifolds are available in 2 to 10 stations.

To calculate the overall length "L" of the manifold use the following formula:

$$L = 2 \times 1.16 + (S-1) \times 1.224$$

Where S = the number of manifold stations

EXAMPLE: 7 Station Manifold:

$$L = 2 \times 1.16 + (7-1) \times 1.224$$

$$L = 9.664 \text{ in. } [245.47 \text{ mm}]$$

## Circuit Board Regulators — Mounting and Packaging

Mounting	Product Configuration	Accessories
DIN Tray	Product mounted in DIN Tray	None
Panel	Product configured for panel mounting	For 'flush' mounting, order Flush Mount Bracket (161-520-00) separately
Multi-Unit Manifold	Product configured for multi-unit manifold mounting	Order Multi-Unit Manifold (350-110-XX) separately. XX = # stations.

## Weatherproof Regulator Mounting Options

The Type 3200 and 3500 regulators can be mounted in-line or by brackets which are available separately (DIN-rail bracket – 010-115-00; Panel bracket – 010-135-00). Bracket mounting holes (2 X 8-32 UNC 2B X 0.375" / 9.5mm deep minimum) are available on the rear and right faces (when looking at product with IN/OUT flow from left to right) and also on the bottom of the medium-flow booster (shown in diagram).

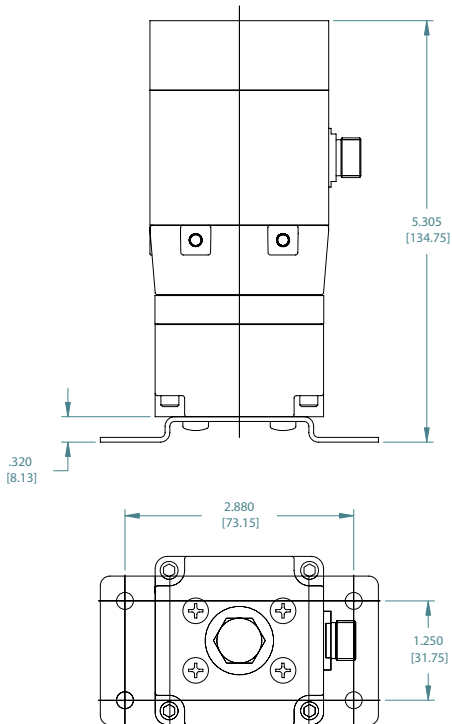

## Low-Flow Weatherproof T3210, T3220, T3510, T3520

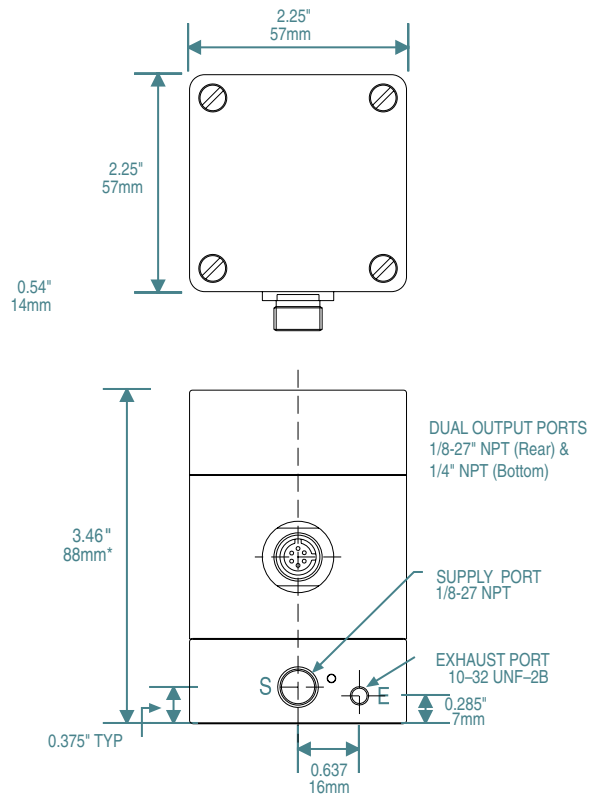

\* High Pressure (>300 PSIG / 20.7BAR) & DeviceNet units are 5.00" / 127mm tall.

### Medium-Flow Weatherproof T3211, T3221, 3511, 3521

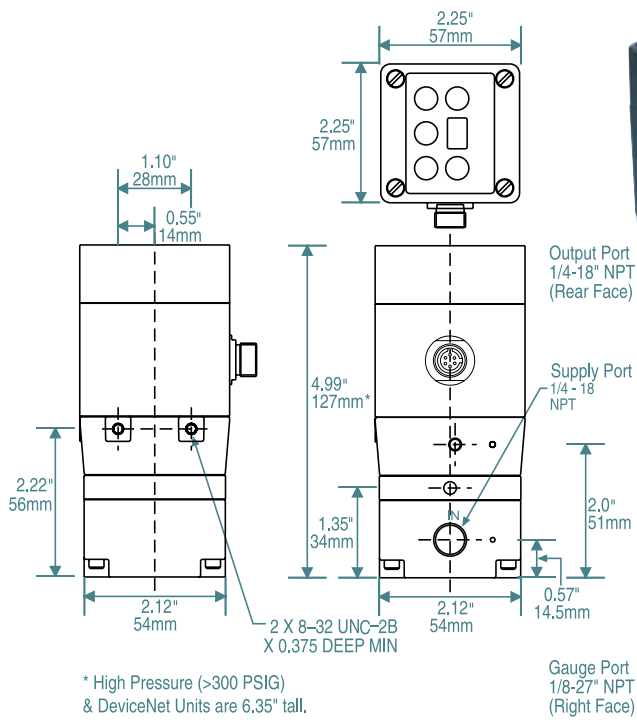

### Manifold Mount T3211, T3221, 3511, 3521

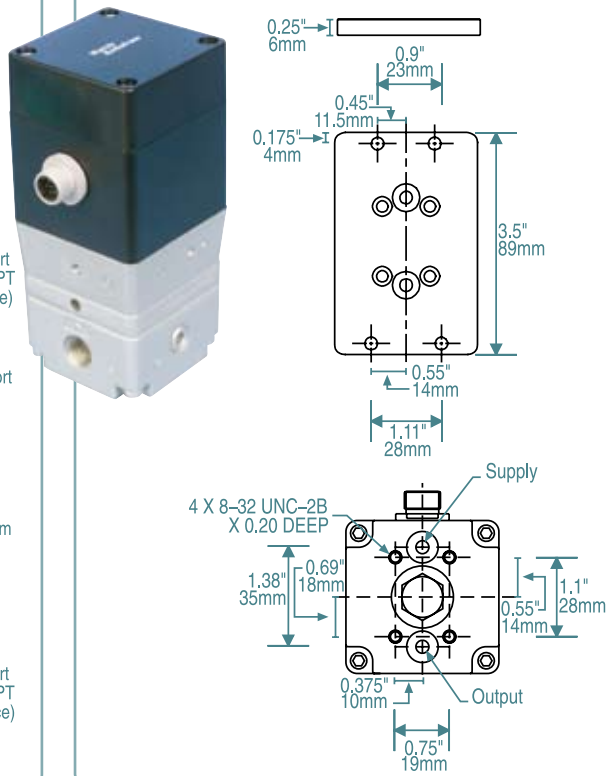

### High-Flow Weatherproof T3212, T3222

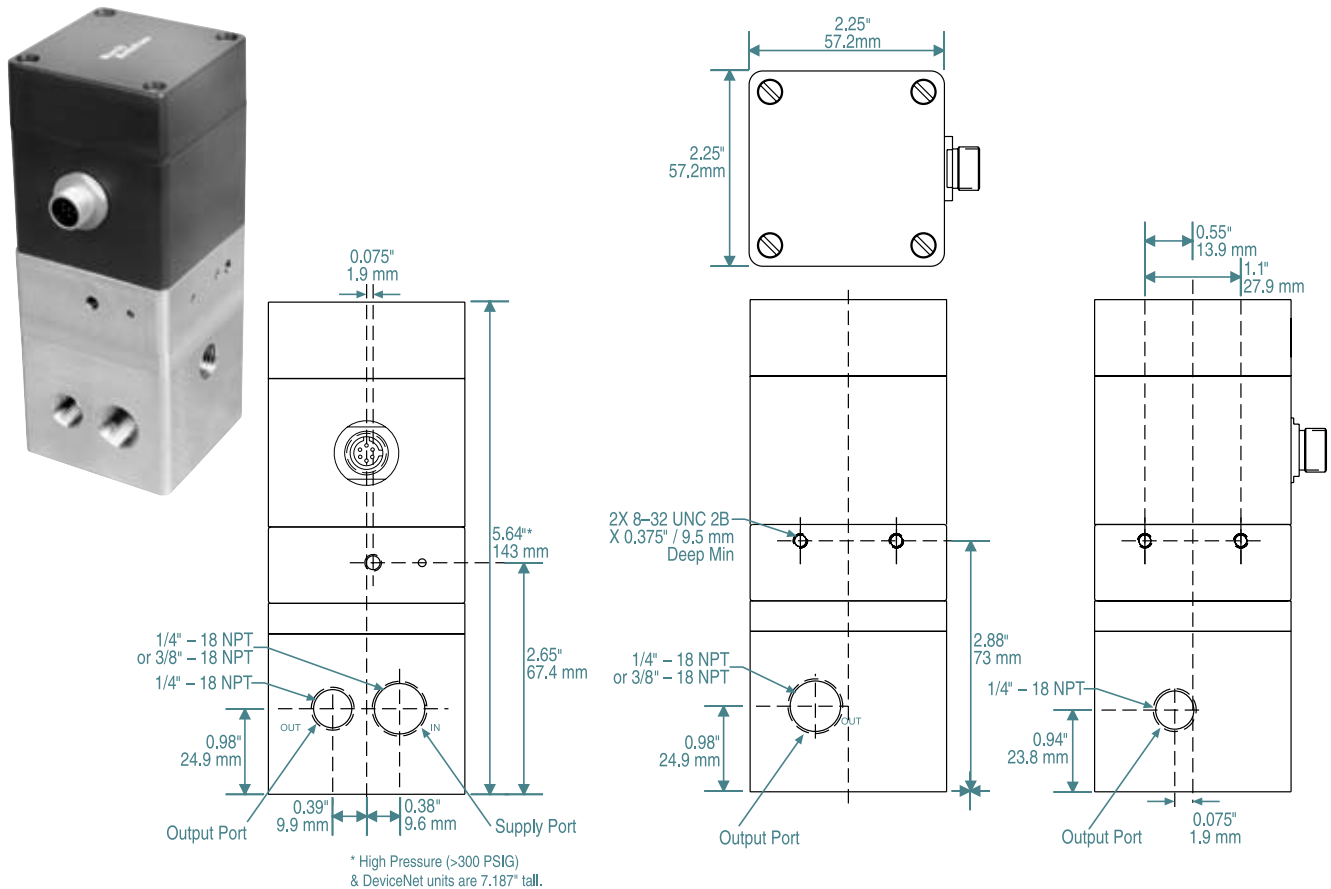

# Remote Pressure Sensors

(RPS)

## Description

The RPS is designed for connection to the T3000's 2nd loop input. When used to monitor pressure at the output of an external volume booster, or directly at the user's remote application, the RPS sensor increases overall accuracy and speed of response to downstream changes.

Pressure ranges from vacuum to 1000 PSIG / 69 BAR are available. RPS outputs (0-10V or 4-20 mA) are field-adjustable. 4-20 mA versions require 12-24 VDC external power, while 0-10V versions require 15-24 VDC. The RPS weatherproof housing is 1.8" / 46mm wide X 2.6" / 66mm tall (for pressures above 300 PSIG / 20.7 BAR, extended height housing is required). The RPS can be directly mounted to the application with its male 1/4 NPT pneumatic connection, or with the SPC-MB1 bracket (available separately).

Temperature range is 0-50 °C.

## Part Numbers: RPS 0GXXX YYYY ZZ

XXX = upper end of pressure range (e.g., '030' for 30 PSIG)

YYYY = electrical output ('0E10' for 0-10V or '4I20' for 4-20 mA)

ZZ = length of wiring ('W' for 3' or 'W6' for 6')

\*Full scale ranges:

1, 5, 15, 30, 100, 150, 300, 500, 1000 PSIG

0.07, 0.3, 1.0, 2.1, 6.9, 10.3, 20.7, 34.5, 69 BAR

Vacuum (29" Hg)



## Sensor Wiring Diagrams

### 0E10

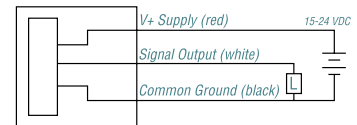

### 4I20 Model

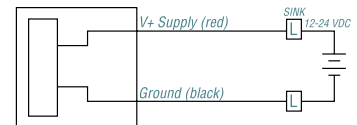

## Cable Applications

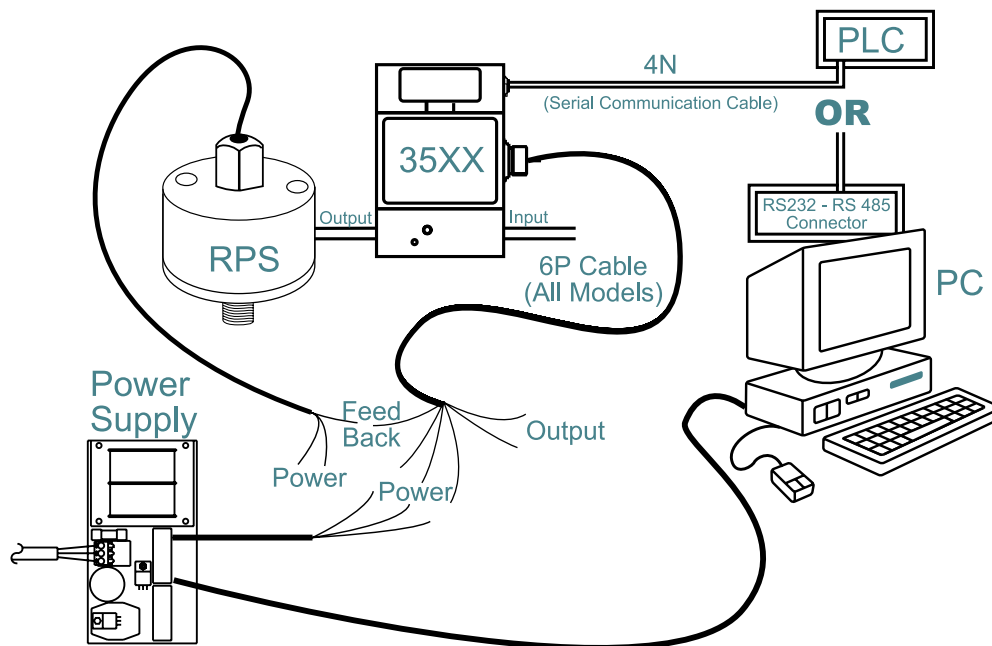

# Cordsets

## DC Power and Analog I/O

Required on all T3200 and T3500 transducers. Single-ended cordset with 6-pin female M12 micro-style connector.

Length of Wiring	Part Number
3' (0.9m)	122-004-08
6' (1.83m)	122-004-09
12' (3.66m)	122-004-10
20' (6.10m)	122-004-11

## DC Power and Analog I/O

Required on Z-option Type 3215.

Single-ended cordset with 4-pin female M12 micro-style connector.

Length of Wiring	Part Number
3' (0.9m)	122-004-04
6' (1.83m)	122-004-05
12' (3.66m)	122-004-06
20' (6.10m)	122-004-07

## Serial RS-485

Required on all T3500 Serial RS-485 transducers.

Single-ended cordset with 4-pin female nano-style connector.

Length of Wiring	Part Number
6.5' (2m)	122-000-00
16.5' (5m)	122-000-01

## DeviceNet

Required on all T3500 DeviceNet transducers.

Single-ended cordset with 5-pin female M12 micro-style connector.

Length of Wiring	Part Number
3' (0.9m)	160-560-01
16.5' (5m)	122-000-01



Cordsets

# Converters

## RS-232 Converter

Converts T3400/T3500 Serial RS-485 interface to RS-232. Part Number: 160-700-00.

## USB Converter

Used in combination with RS-232 Converter, allows connection of T3400 or T3500 Serial to USB port. Part Number: 160-710-00



Converters

# Power Supplies & Control Knobs

A pair of 15VDC circuit-card power supplies is available for integration of Type 3000 transducers into 120VAC systems. The ZMS-JR powers a single Type 3000; the ZMS15-2 powers up to two. In addition, the ZMS15-2 can control a pair of Type 3000 transducers with 0-10V when combined with the P1 Control Knob.

The ZMSJR is rated at 375 mA maximum output; the ZMS15-2 at 750mA. Connections are made via removable terminal blocks. Both power supplies are short circuit protected, and mounted in trays for easy DIN rail mounting. The ZMSJR (without DIN tray) can also be

standoff mounted. AC power cords are included. The ZMS-JR has a 3.6" / 91mm X 3.1" / 79mm footprint and is 2.6" / 66mm high when mounted in its DIN tray; the ZMS15-2 is 5.4" / 137mm X 3.1" / 79mm and 2.7" / 69mm.

		Part Number
ZMSJR	Powers one Type 3000	501-200-04
ZMS15-2	Powers and Controls two T3000's	501-200-00
P1-3	Control Knob with 3' (0.91m) wiring	504-100-00
P1-6	Control Knob with 6' (1.83m) wiring	504-100-01
P1-12	Control Knob with 12' (3.66m) wiring	504-100-02



# Applications

## Doctor Blade Control

Doctor blades are used through-out the paper process to remove water and contaminants from the roll. The use of a double-acting cylinder (or bladders or bellows) on each end of the roll, with two T3512's controlling the position of each cylinder, increases the positioning accuracy of the doctor blade.

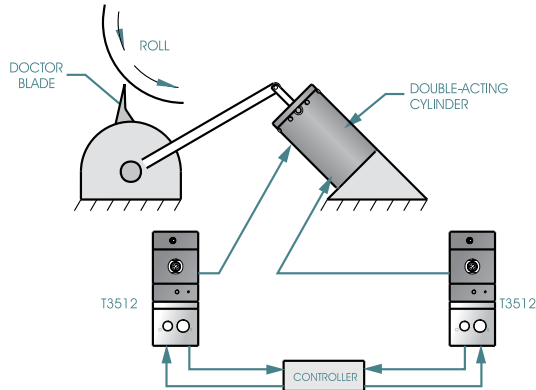

## Web Tension

A web-tensioning system serves as a kind of shock absorber, keeping the web at the same tension no matter what the roll size. The T3522 utilizes closed-loop feedback from the dancer arm, to adjust pressure delivered to the pneumatic brake, keep the dancer arm at the desired position, and maintain the desired web tension. The two-loop capability of the T3522 frees up the Controller for other tasks.

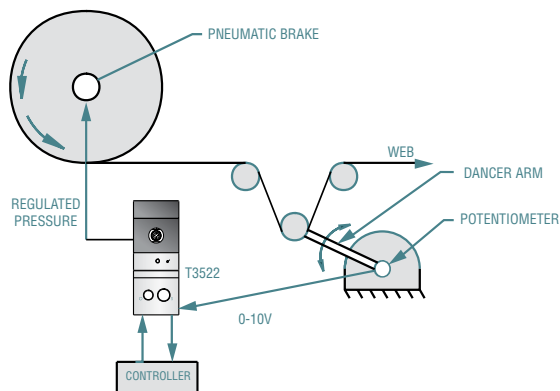

## Web Caliper (Thickness)

In the calendar section of the paper machine, the T3512 regulates pressure delivered to an air cylinder (or bladder or bellows) to regulate the thickness of the paper. The calendar section consists of calendar stacks with a reel device for winding the paper onto a reel as it leaves the machine. The calendar finishes the paper by smoothing it to the desired finish, thickness, or gloss.

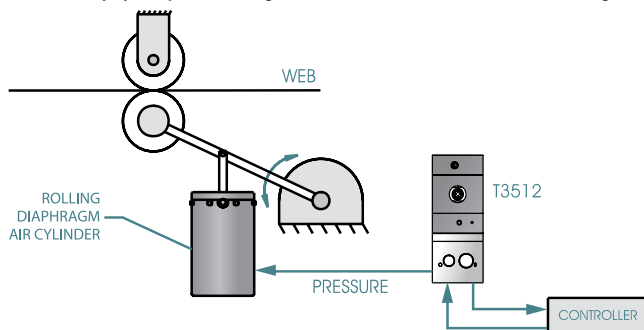

## Tire Molding

During the vulcanization stage of tire making, a green tire is molded into a finished tire – ready for testing, inspection, and shipment. Tight control of pressure and temperature is absolutely critical to the making of high-quality tires. This requires valves for steam, cold water, and air pressure, as well as devices to monitor pressure and temperature. In the illustration, the T3510P I/P is mounted in the cabinet with the PLC, to locate all the electronics in a single location. The T79V volume booster provides the flow capacity to open and close the valve rapidly, as well as a 'tunable' integral needle valve to provide stable operation.

Other products used in tire molding include filter-regulators (T51), regulators (T70 and T78), and Positive-Bias Relays (T72).

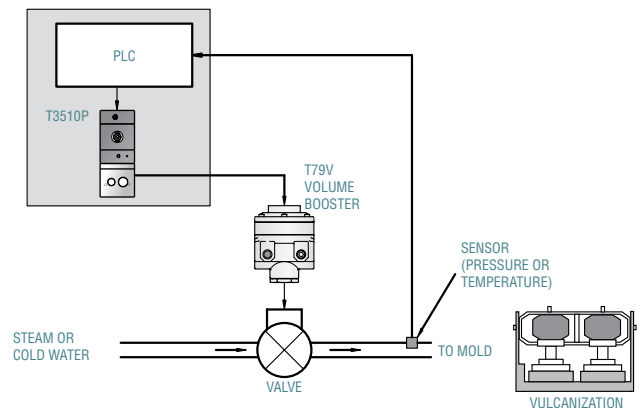

## Valve Control

Valves are used throughout the paper-making process to control the flow of water, steam, pulp, and chemicals. Valves are found in Water Treatment facilities (both incoming and outgoing), as well as Power Generation facilities. Some paper mills install steam-shower valves after the dryer section to control paper curl.

Valves can be actuated by Valve Positioners, I/P Electro-Pneumatic Transducers, or both. In the example below, the Type 3210 is used to regulate the amount of water (or other fluid) passing through a valve. The T3210 receives a control signal from a Programmable Logic Controller and regulates the speed and position of the valve actuator. The T79V Volume Booster increases valve opening/closing speed by increasing dramatically the amount of compressed air being fed to the actuator. Other products used in valve control include Filter-Regulators (T50 and T51), Regulators (T70), Positive-Bias Relays (T72), P/I Transducers (T5000), and pressure gauges.

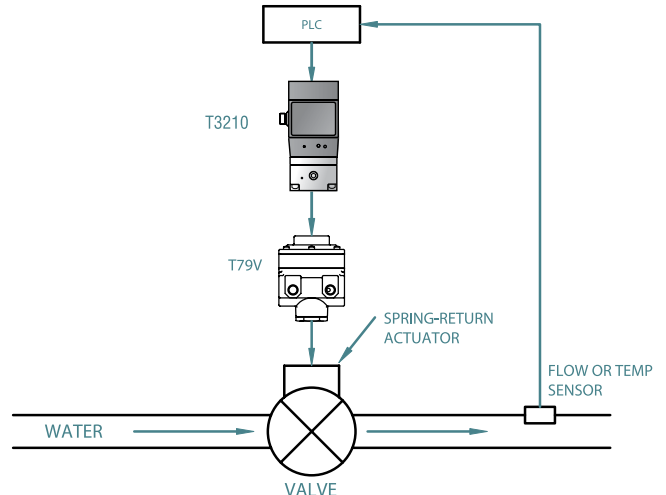

## Edge-Guiding and Web-Break Detection

The Controller uses feedback from an infrared edge detector to control horizontal web position. The T3512 controls the extension of a cylinder (or bladder or bellows) which moves the web from side to side. In the event of a web break, the output of the edge detector signals the Controller to begin remedial action. The T1000 (or T1500) supplies a steady stream of air to keep the edge detector's sensing elements free of contamination.

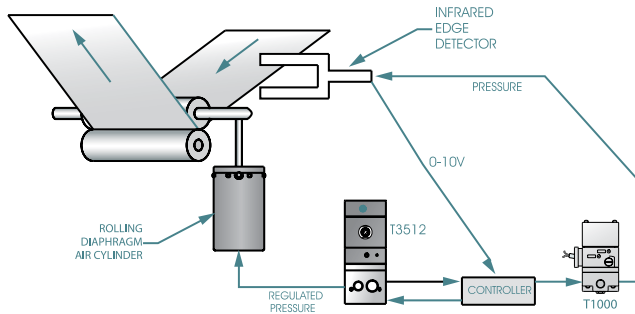

## Edge Guiding

### Using a Web Sensor and Type 3221

As the web position varies, the web sensor detects the change and feeds a signal back to the Type 3221 Pressure Controller. The Type 3221 then applies pressure to the cylinder to compensate for the shift in web position. The ZMS15-2 Power Supply provides both the command signal and the supply voltage that sets the initial web position while allowing for adjustments.

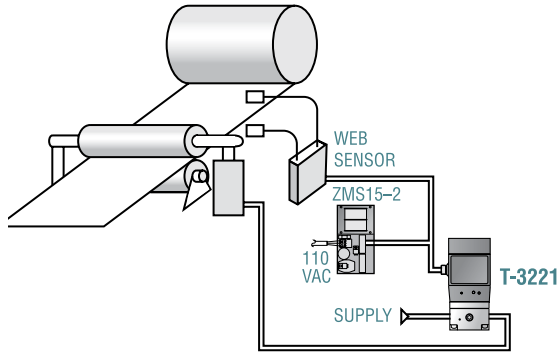

## Sidewall Grinding

### Using the Type 3212

A Type 3212 provides pressure control in a tire sidewall grinding application. A command signal is channeled through a ZMS15-2 Power Supply which feeds the command signal as well as the 15 volts DC supply voltage to the Type 3212. A gauge monitors the downstream pressure of the Type 3212, with a relief valve to protect against over pressurization.

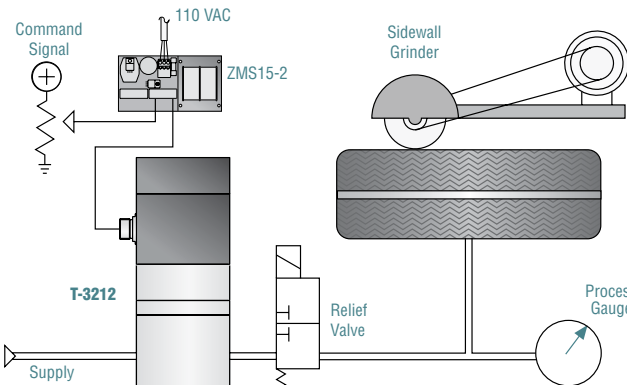

## Tire Testing

Most manufacturers run finished tires through a battery of tests and inspections. To minimize total testing time, multiple tires must be inflated and deflated very rapidly, with pressure held constant during the testing.

In the illustrated example, the PLC begins the test by sending a setpoint to the T3220 electronic pressure controller. The T20 pre-amplifies the flow of the T3220, to provide tight responsive control of pressure delivered to the High Flow Booster. The T3220 and T20 can be ordered as a single integrated unit.

The High Flow Booster is selected based on the size and number of tires to be tested. Marsh Bellofram has a full range of flow boosters up to 2" port size and 2000 SCFM / 56640 SLPM.

In order to maintain the highest accuracy, the RPS pressure sensor is mounted close to the tire. The T3220's two-loop capability allows it to close the loop with the downstream sensor, freeing up the PLC for other things.

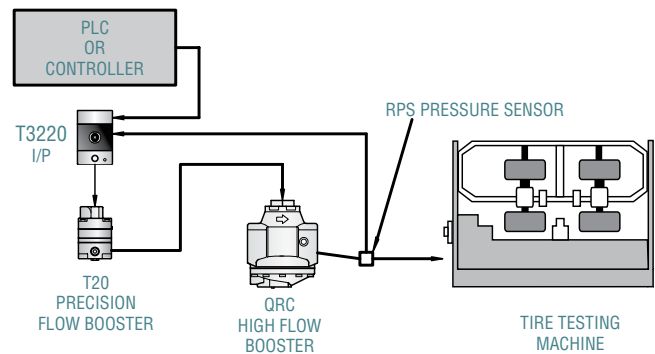

## Hot Stamping Force Control

### Using the Type 3211

The Type 3211 pressure controller applies pressure to the cylinder to develop a force for the hot stamping operation. In this configuration, the ZMS15-2 Power Supply provides both the command signal and supply voltage necessary to control the Type 3211. A programmable controller may also supply this command signal.

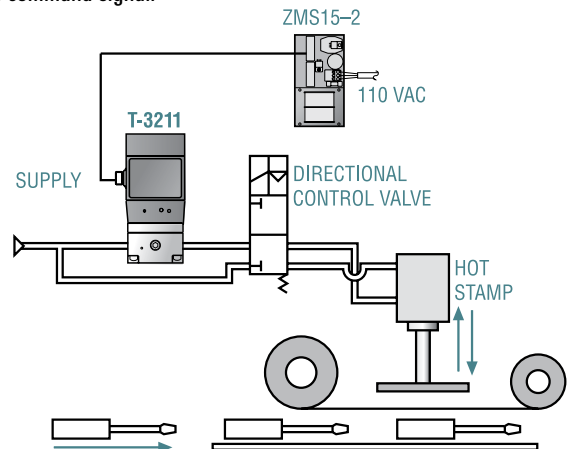

## Air Over Oil Speed Control

### Using the Type 3211

The Type 3211 varies the cylinder speed by varying the pressure in the air over oil tanks. The ZMS15-2 Power Supply provides both the command signal and the supply voltage to the Type 3211. The output pressure, through a directional control valve, controls the speed at which the cylinder extends and retracts.

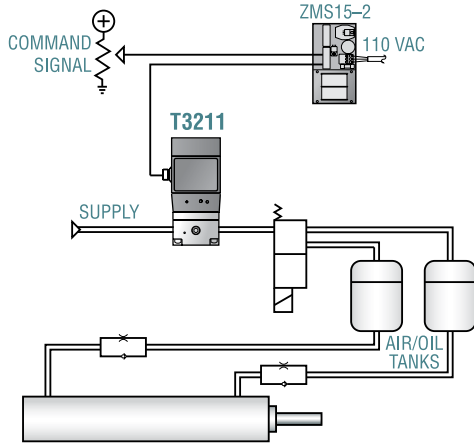

## Surface Winding Control

### Using the Type 3110

As the roll diameter and the cylinder position change, the feedback arm moves the rotary potentiometer. This rotary potentiometer output changes the regulated output pressure of the Type 3110 to control the pressure to the surface wind cylinder.

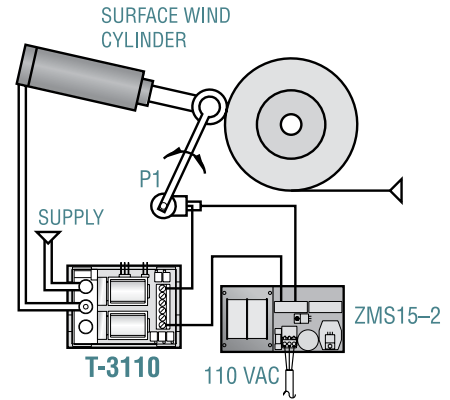

## Adhesive Dispensing

### Using the Type 3511

The Type 3511 pressure controller, after receiving its signal from the PLC, applies air pressure to the glue pot. This in turn controls the glue pressure and flow to the automatic glue dispensing machine. A sensor in the automatic glue dispensing machine provides feedback to the PLC for fine tuning of the application.

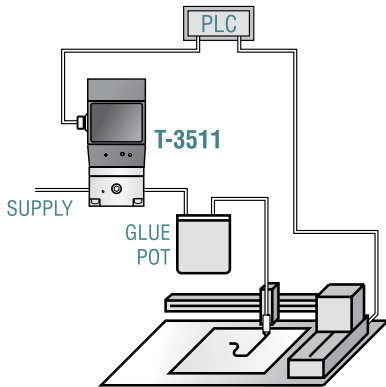

## Surface Mount Force Control

### Using the Type 3210

The Type 3210 Pressure Controller can provide precise control of force for automated placement of surface mount IC's. In this application, an SMD Machine Controller sets the pressure for each chip placement.

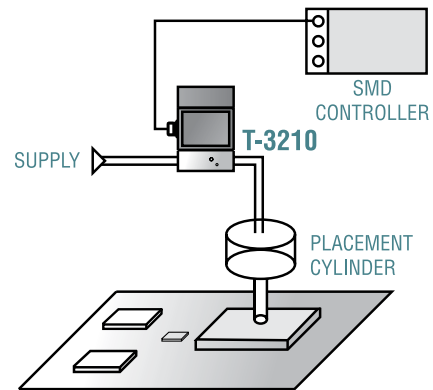

## Electronic Control of Vacuum Through Pressure

### Using the Type 3210

The Type 3210 can be calibrated to operate in both the vacuum and pressure ranges. The ZMS15-2 Power Supply provides the Type 3210 with the command signal and supply voltage. Supply pressure is routed to both the vacuum generator and the Type 3210 with an on-off switch in front of the vacuum generator. The Type 3210 then can regulate both vacuum and pressure to the chamber. A compound gauge monitors the pressure in the chamber.

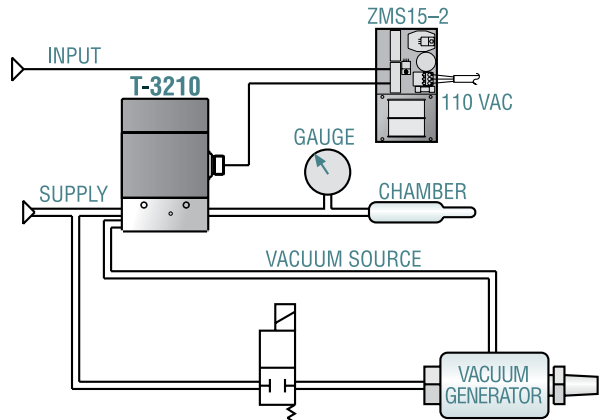

## Electronic Control of Vacuum

### Using a Type 3110

The Type 3110 is used to control pressure to a vacuum process chamber. A control potentiometer channels the command signal through a ZMS15-2 Power Supply to operate the Type 3110. A vacuum gauge is used to monitor the regulated vacuum from the Type 3110.

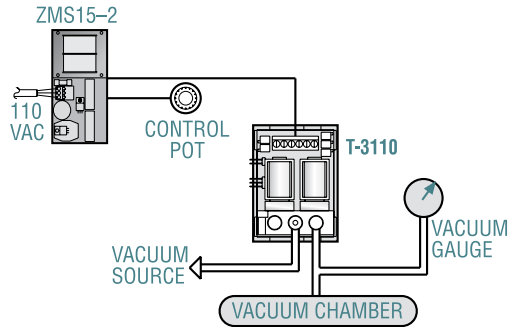

## Automated Pressure Switch Calibrator

### Using a Type 3510

The Type 3110 is used to control pressure to a vacuum process chamber. A control potentiometer channels the command signal through a ZMS15-2 Power Supply to operate the Type 3110. A vacuum gauge is used to monitor the regulated vacuum from the Type 3110.

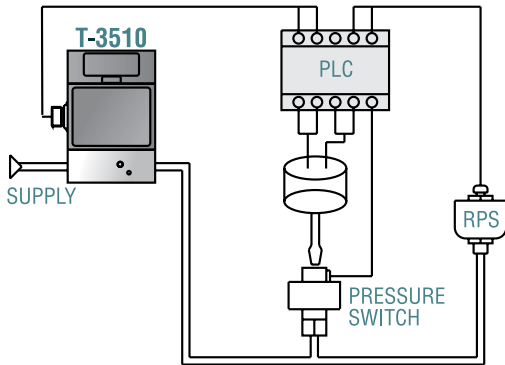

## Control of High Flow, Low Pressure

### Using the Type 3220

This circuit provides an adjustable control of clamping force that is directly proportional to the tension of the material being stretched by the servo motor. The initial clamping pressure is set by the process controller and as the servo motor applies tension to the material being tested, the load cell's output signal commands the Type 3510 pressure controller to increase the clamping force.

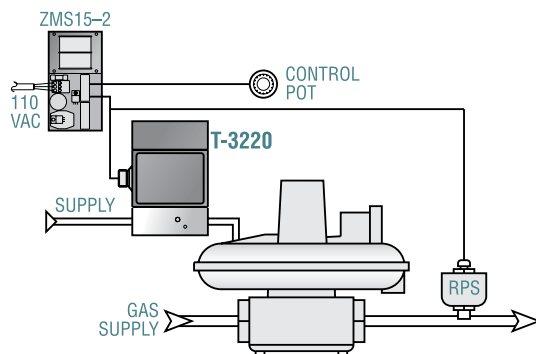

## Liquid Level Control

### Using the Type 3521

The ultrasonic sensor provides feedback to the Type 3521 for controlling the liquid level of an ink tank. The liquid level setpoint is controlled by the PLC by varying the command signal to the Type 3521.

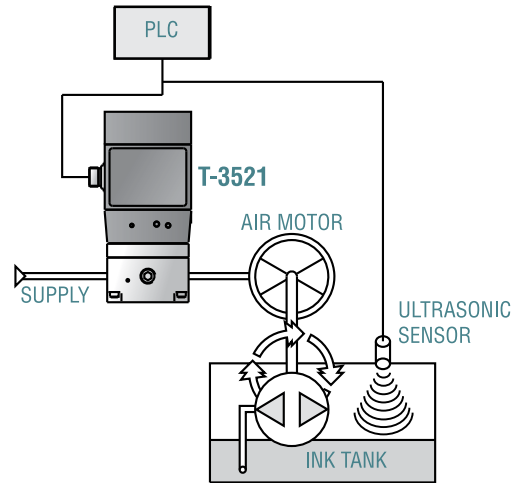

## Clamping Force Control

### Using the Type 3510

This circuit provides an adjustable control of clamping force that is directly proportional to the tension of the material being stretched by the servo motor. The initial clamping pressure is set by the process controller and as the servo motor applies tension to the material being tested, the load cell's output signal commands the Type 3510 pressure controller to increase the clamping force.

